

Nema 17

2 phase 1.8° step angle
 hybrid stepping motor

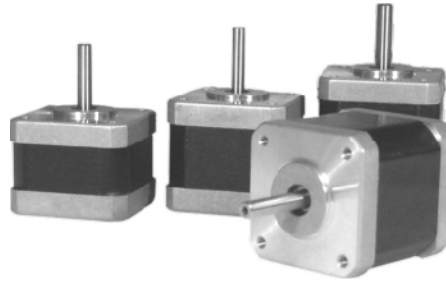

Specifications:

Model	Holding Torque (Nm)	Phase current (A)	Rotor Inertia (g/cm ²)	Motor Length L max (mm)	Detent Torque (Nm)	Phase Resistance (ohm)	Phase Inductance (mH)	Lead Wire (No)	Motor Weight (Kg)	Note
M1173020	0.28	0.7	34	34	0.016	6.3	8.9	4	0.24	
M1173021	0.28	1.3	34	34	0.016	2.6	3.7	4	0.24	
M1173030	0.40	0.7	54	40	0.022	7.5	15.3	4	0.29	
M1173031	0.40	1.7	54	40	0.022	1.45	2.6	4	0.29	
M1173040	0.50	0.7	68	48	0.026	9.3	17.8	4	0.35	
M1173041	0.50	1.7	68	48	0.026	1.78	2.9	4	0.35	

Double shaft and custom windings available

Mechanical Dimensions:

Unit: mm

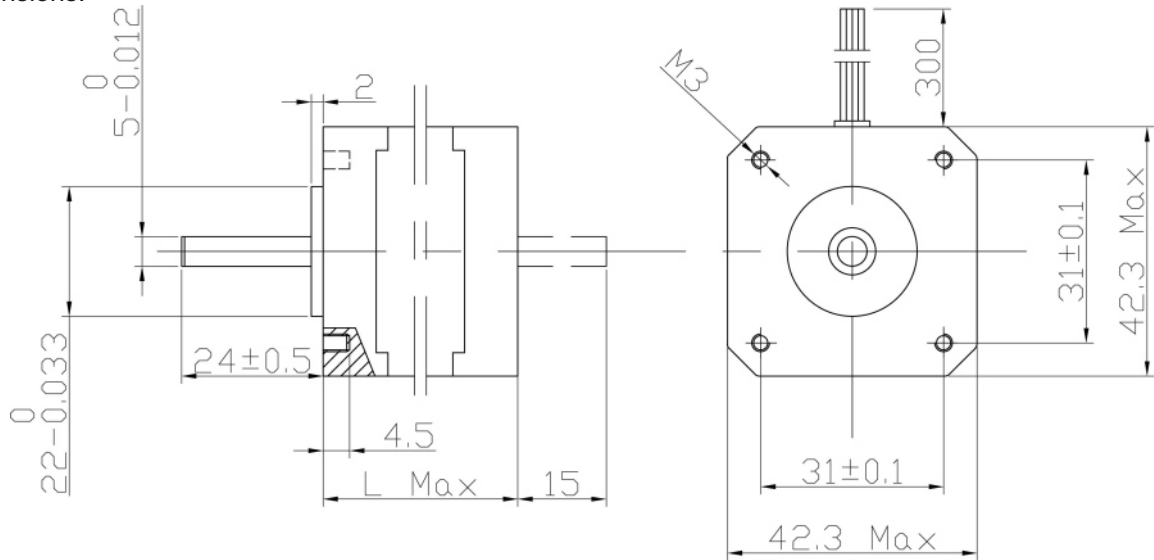

Wiring Diagram:

