

## FEATURES

- Normally closed contactor for capacitor discharge and other dump switch applications requiring normally closed contacts
- Small, low cost solution for HVDC Discharge applications
- Designed to meet CE Conformance standards
- Not position sensitive – can be mounted in any position for ease of installation
- Designed and manufactured in Carpinteria, CA USA

## PRODUCT SPECIFICATIONS

Specifications	Units	Data
Contact Arrangement	Form Y	SPST-NC
Dielectric at Sea Level	Vrms	4300
Contact Voltage, Operating Max	Vdc	1500
Continuous Current Carry, Max (8 AWG) @ 25°C	A	30
Continuous Current Carry, Max (8 AWG) @ 85°C	A	15
Electrical Life (Resistive Load) Make and Break, 20A @ 400Vdc	Cycles	6000
Mechanical Life	Cycles	100,000
Contact Voltage Drop, Max @ 50A	mV	100
Contact Resistance @ 50A	mOhms	2
Operate Time, Max	ms	25
Release Time, Max	ms	8
Vibration, Sinusoidal (50-200Hz Peak)	G	5
Shock, Operating, 1/2 Sine, 11ms	G	20
Temperature, Operating Range <sup>1/</sup>	°C	-40° to +85°
Humidity, No Freezing or Condensing at Low Temperature	RH	5% to 85%
Weight	grams	135
Short Circuit Current Withstanding (5ms)	A	400
Impulse Withstand Voltage: IEC61000-4-4 (500 ohm)	kV	6

## POWER SWITCHING AND CURRENT CARRY RATINGS

DC RESISTIVE CLOSING CYCLE ESTIMATES (MAKE ONLY)

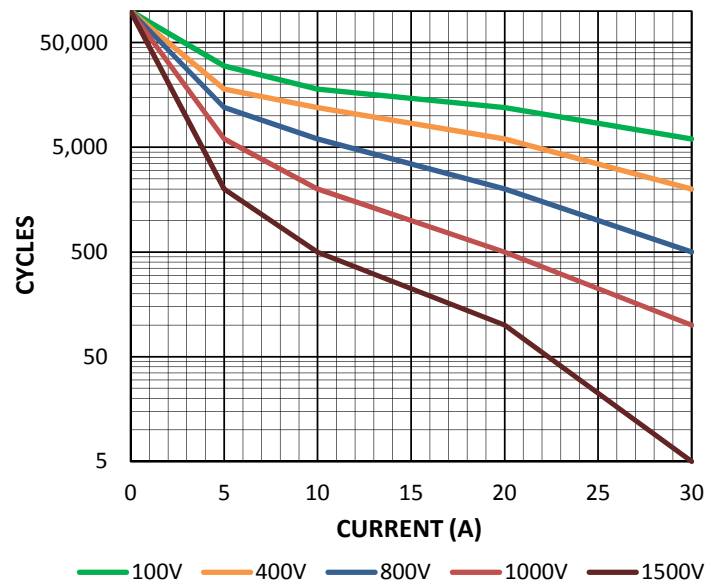

CURRENT CARRY

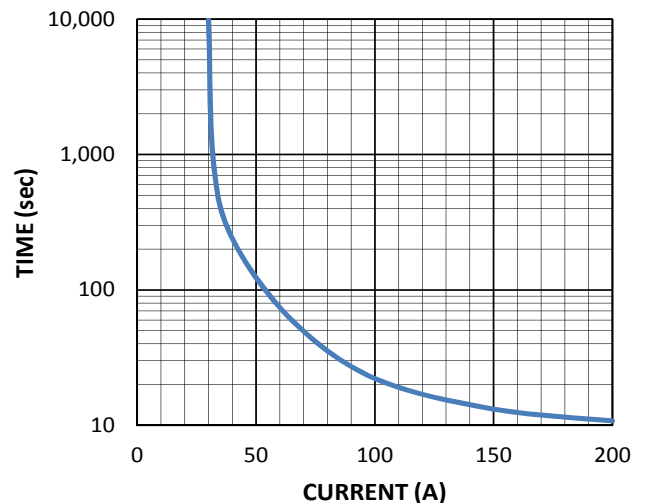

## COIL RATINGS @ 25°C <sup>2/</sup>

Coil P/N Designation	B	C	F
Coil Voltage, Nominal	12 Vdc	24 Vdc	48 Vdc
Coil Voltage, Max	16 Vdc	32 Vdc	64 Vdc
Pick-up Voltage, Max	7.5 Vdc	15 Vdc	30 Vdc
Drop Out Voltage, Max	5 Vdc	9 Vdc	18 Vdc
Drop Out Voltage, Min	0.20 Vdc	0.40 Vdc	0.80 Vdc
Coil Resistance, +/-10%	70 Ohms	280 Ohms	1092 Ohms
Coil Current at Nominal Voltage	0.170 A	0.085 A	0.045 A
Recommended External Coil Suppression (not included)	SMAJ40CA or P6KE47CA-E3/54	SMAJ40CA or P6KE47CA-E3/54	SMAJ100CA or P6KE120CA



**DIMENSIONS**

**Mounting**

M4 or 8-32 Screws  
Torque 1.3-1.7Nm [12-15in-lb]

**Case Material**

Thermoplastic Polyester Resin

**Power Connection**

M4 Studs  
Torque 1.3Nm [12in-lb] max

**Coil Termination**

M3 Studs  
Torque 0.5Nm [5in-lb] max

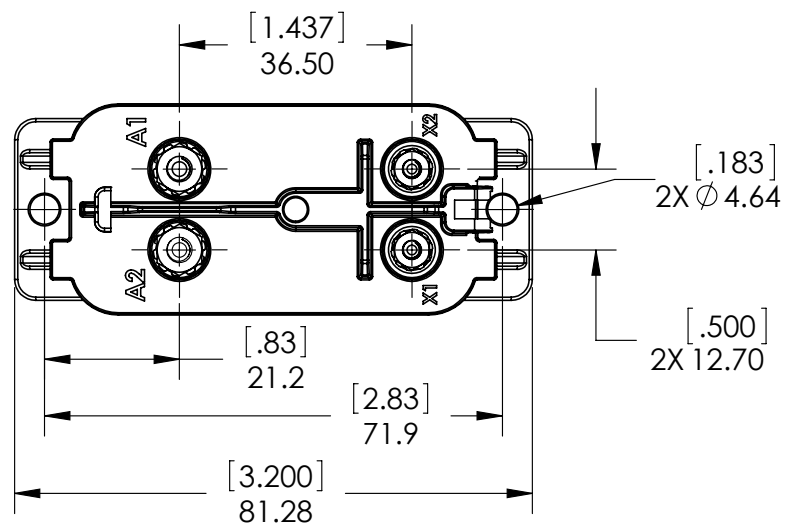
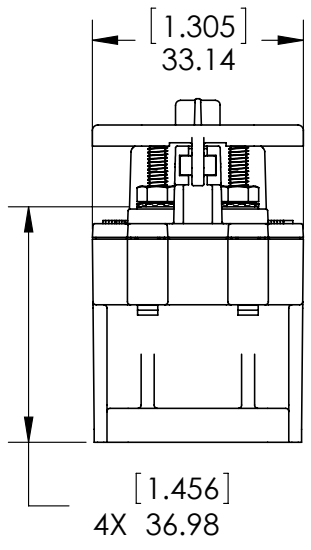
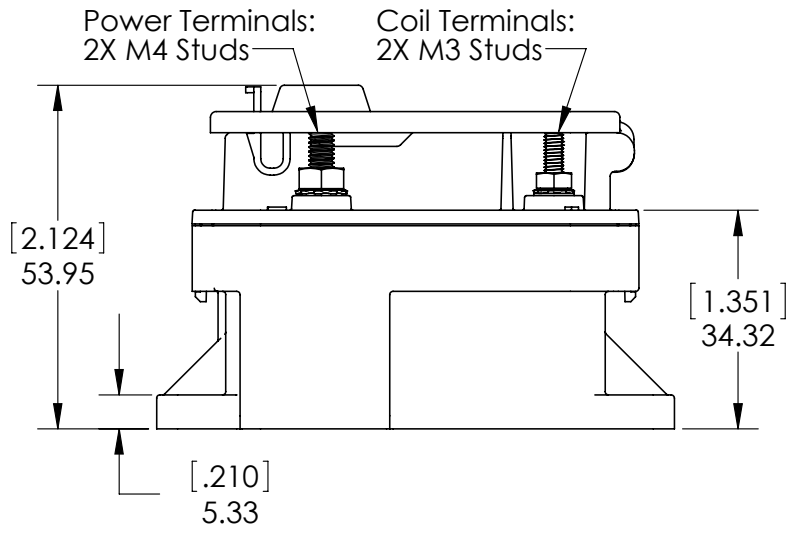

## PART NUMBER SYSTEM

PNC113	B	D	A
Coil Voltage	B=12 Vdc		
	C=24 Vdc		
	F=48 Vdc		
Coil Terminals		D=Studs, M3	
Power Terminals			A=Studs, M4

### Notes & Definitions:

**1/** Temperature range refers to ambient conditions. Terminal temperature can exceed listed values.

**2/** Contactor is operated by a coil that changes resistance with temperature. Since pick-up current, coil current and coil power are specified at nominal voltage, they will be lower than indicated at temperatures above 25°C and higher than indicated at temperatures below 25°C. Similarly, pick-up and drop-out voltages will be higher than indicated at temperatures above 25°C and lower than indicated at temperatures below 25°C.

## APPLICATION NOTES

Electrical life rating is based on resistive load with 27μH maximum inductance in circuit. Because your application may be different, we suggest you test the contactor in your circuit to verify life is as required.

Contactor is bi-directional and therefore can carry, make, and break current in both directions.

Contactor is not sensitive to direction of installation and can be mounted in any position or axis.