



PTDM6

Inclination sensor with robust stainless steel housing



- Measurement range up to $\pm 180^\circ$
- Single or dual axis measurement
- Protection class IP67/IP69
- Hermetically sealed stainless steel housing
- Potted electronics
- Wear-free MEMS technology, shock resistant

Product version



Digital output CAN



PTDM6 - Inclination sensor in MEMS technology
Version with digital output CAN

Specifications

		Order options
Output	CANopen (Profil „inclinometer“) CAN SAE J1939	1 CANOP CANJ1939
Measurement range	±180° with 1 axis ±60° with 2 axes	
Resolution	0.05°	
Linearity	±0.5°	
Output delay	0.1 s ... 10 s / 90%, configurable	
Mounting	Screws M6	
Protection class	IP67/IP69 (connector output with IP69 connector)	
Connection	Connector M12 axial, 5 pin Connector M12 radial, 5 pin	2 M12A5/CAN M12R5/CAN
Housing material	Stainless steel EN 1.4404 (AISI 316L)	3 VA
Shock	DIN EN 60068-2-27:2010, 100 g/11 ms, 100 shocks	
Vibration	DIN EN 60068-2-6:2008, 20 g 10 Hz-2 kHz, 10 cycles	
Temperature range	-40° ... +85°C	
Weight	approx. 390 g	
EMC	DIN EN 61326-1:2013	

Order code

PTDM6 – **1** – **2** – **3**

Order example: PTDM6 – CANOP – M12A5/CAN – VA

Accessories:

Connector cable (see page 8)

Dimensions

Connector M12, axial

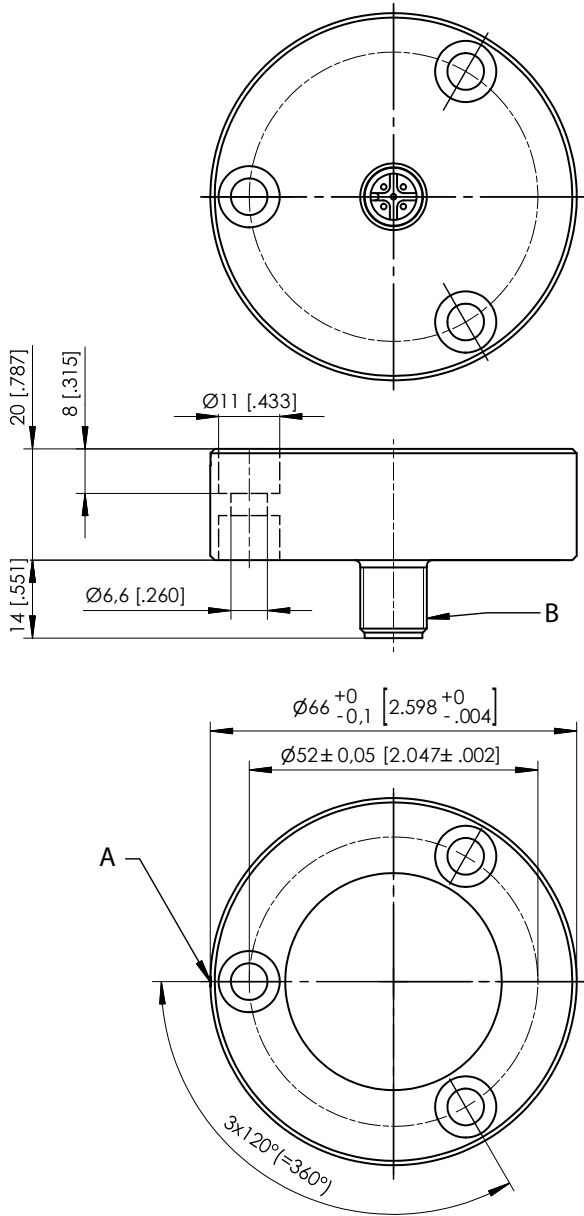

A – Marking
B – Connector M12

Dimensions in mm [inch].
Dimensions informative only.
For guaranteed dimensions consult factory.

Connector M12, radial

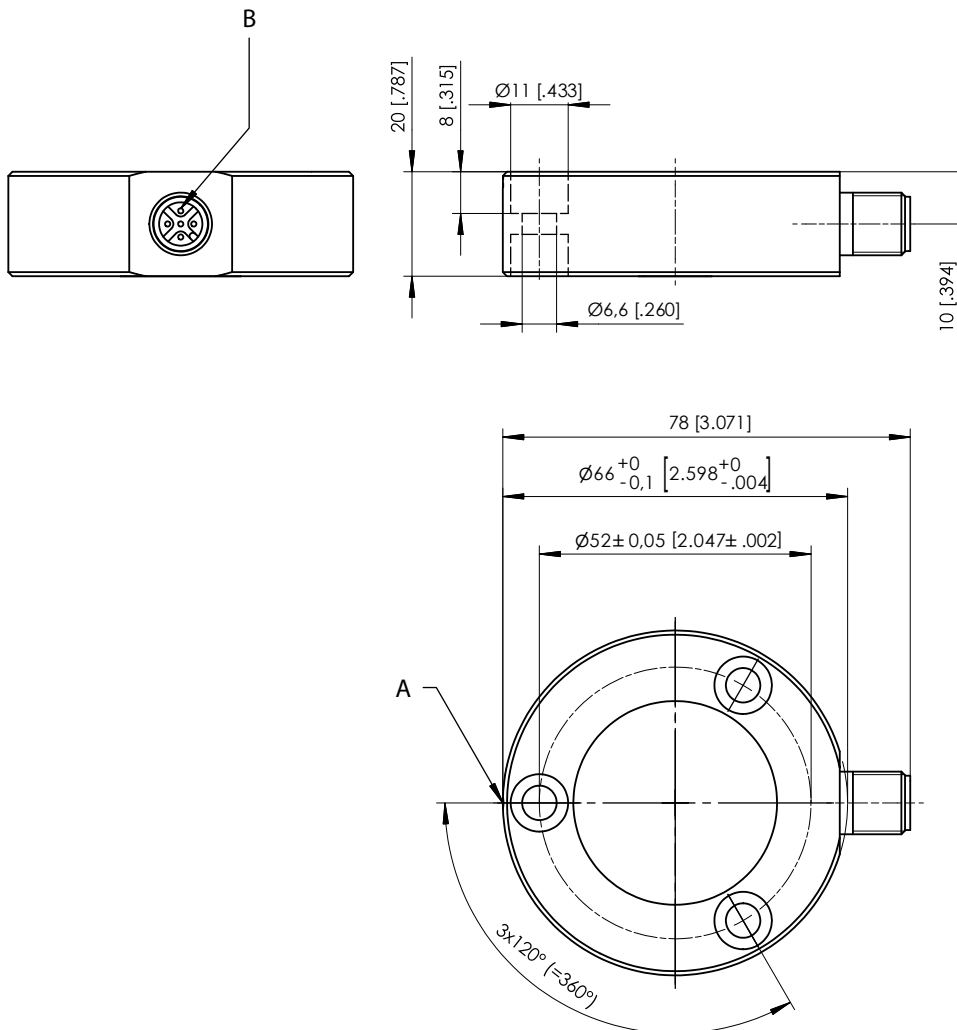

A – Marking
B – Connector M12

Dimensions in mm [inch].
Dimensions informative only.
For guaranteed dimensions consult factory.

Output specification

CANOP CANopen 	Communication profile	CANopen CiA 301 V 4.02, Slave
	Encoder profile	CiA 410 V 1.2, Profile „Inclinometer“
	Configuration services	LSS, CiA Draft Standard 305 (Transmission rate, node ID)
	Error Control	Node guarding, Heartbeat, Emergency message
	Node ID	Adjustable via LSS or SDO, default: 127
	PDO	1 TxPDO, 0 RxPDO, no linking, static mapping
	PDO Modes	Event-/Time triggered, Remote-request, Sync cyclic/acyclic
	SDO	1 Server, 0 Client
	Certified	yes
	Transmission rate	50 kBit ... 1 Mbit, adjustable via LSS or SDO, default: 125 kBit
	Bus connection	M12 connector, 5 pin
	Bus with integrated terminating resistance	optional
	Bus, galvanic isolated	no

Specifications	Excitation voltage	8 ... 36 V DC
	Excitation current	15 mA typical at 24 V DC 30 mA typical at 12 V DC 100 mA max.
	Measuring rate	1 kHz (standard)
	Stability (temperature)	$\pm 100 \times 10^{-6}$ / °C f.s.
	Repeatability	1 LSB
	Operating temperature	-40 ... +85 °C
	Protection	Reverse polarity, short circuit
	EMC	DIN EN 61326-1:2013

Signal wiring	Output signals	Connector pin no.
Connector M12, 5 pin  View to the sensor connector	Shield	1
	Excitation +	2
	GND	3
	CAN-H	4
	CAN-L	5

CANJ1939 SAE J1939 	CAN specification	ISO 11898, Basic and Full CAN 2.0 B
	Transceiver	24V-compliant, not isolated
	Communication profile	SAE J1939
	Transmission rate	250 kbit/s
	Address	Default 247d, configurable

NAME Fields	Arbitrary address capable	1	Yes
	Industry group	0	Global
	Vehicle system	7Fh (127d)	Non specific
	Vehicle system instance	0	
	Function	FFh (255d)	Non specific
	Function instance	0	
	ECU instance	0	
	Manufacturer	145h (325d)	Manufacturer ID
	Identity number	0nnn	Serial number 21 bit

Parameter Group Numbers (PGN)	Configuration data	PGN EF00h	Proprietary-A (PDU1 peer-to-peer)
	Process data	PGN FFnnh	Proprietary-B (PDU2 broadcast); nn Group Extension (PS) configurable

Specifications	Excitation voltage	8 ... 36 V DC
	Excitation current	15 mA typical at 24 V DC 30 mA typical at 12 V DC 100 mA max.
	Measuring rate	1 kHz (standard)
	Stability (temperature)	$\pm 100 \times 10^{-6}$ / °C f.s.
	Repeatability	1 LSB
	Operating temperature	-40 ... +85 °C
	Protection	Reverse polarity, short circuit
	EMV	DIN EN 61326-1:2013

Signal wiring	Output signals	Connector pin no.
Connector M12, 5 pin  View to the sensor connector	Shield	1
	Excitation +	2
	GND	3
	CAN-H	4
	CAN-L	5

Position of the inclination axis and characteristic of the linear output PTxM6

PTxM6 axial

Connector M12, 1 axis

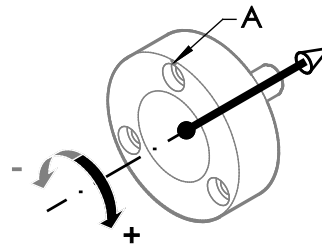

PTxM6 axial

Connector M12, 2 axes

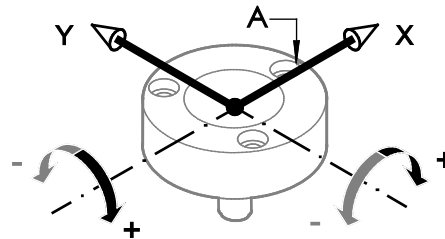

PTxM6 radial

Connector M12, 1 axis

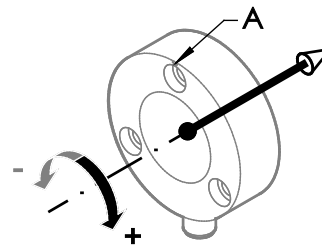

PTxM6 radial

Connector M12, 2 axes

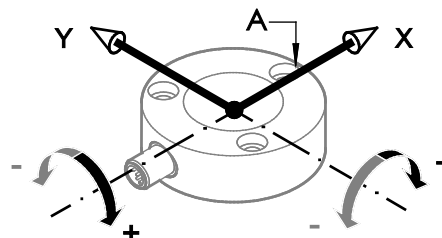

A – Marking

Output signal

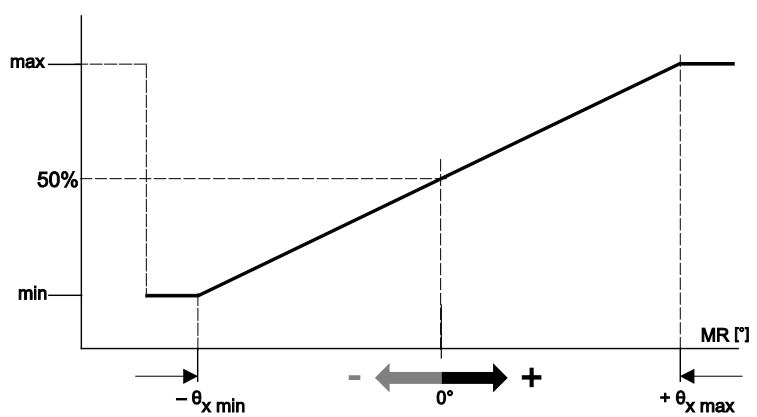

Accessories

Connector/bus cable M12, 5 pin CAN-Bus

The 5-lead shielded cable is supplied with a female 5 pin M12 connector at one end and a male 5 pin M12 connector at the other end.

Available lengths are 0.3 m, 2 m, 5 and 10 m.

Cable diameter: 6.7 ±0.2 mm

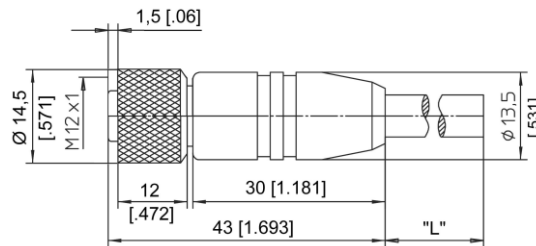

Order code

KAB - xM - M12/5F/G - M12/5M/G - CAN

IP69: **KAB - xM - M12/5F/G/69K - M12/5M/G/69K - CAN**

xM = length in m

T-connector for bus cable M12, 5 pin CAN-Bus

Order code

KAB - TCONN - M12/5M - 2M12/5F - CAN



Terminating resistor M12, 5 pin CAN-Bus

Order code

KAB - RTERM - M12/5M/G - CAN



Applicable for cable carriers

Maximum movement speed	3 m/s
Maximum acceleration	5 m/s ²
Minimum bending radius	10 x cable diameter