



PTAM2

Inclination sensor with robust aluminum housing



- Measurement range up to $\pm 180^\circ$
- Single or dual axis measurement
- Protection class IP67/IP69
- Wear-free MEMS technology, shock resistant
- Servo flange mounting

Product versions



Analog output



Analog output, tare function



PTAM2 - Inclination sensor in MEMS technology
Version with analog output

Specifications

			Order options
Number of axes of inclination	1 axis: Inclination in X axis 2 axes: Inclination in X and Y axes	1	1 2
Measurement range	1 axis: ±15 ... 180° (selectable in 15° increments) 2 axes: ±15 ... 60° (selectable in 15° increments)	2	15 ... 180 15 ... 60
Output	Voltage 0.5 ... 10 V Voltage 0.5 ... 4.5 V Current 4 ... 20 mA, 3 wire	3	U2 U8 I1
Resolution	0.05°		
Linearity	±0.5°		
Mounting	Clamps, mounting plate		
Protection class	IP67/IP69 (connector output with IP69 connector)		
Signal characteristics	Signal increasing CW Signal increasing CCW	4	CW CCW
Output delay	0.1 s ... 10 s / 90%	5	Tx.x
Connection	Connector M12 axial, 5 pin (compatible with 4 pin mating connector) Connector M12 radial, 5 pin (compatible with 4 pin mating connector) Cable, standard length 2 m Deutsch connector, not shielded	6	M12A5 M12R5 KAB2M
Housing material	Aluminum		
Shock	DIN EN 60068-2-27:2010, 100 g/11 ms, 100 shocks		
Vibration	DIN EN 60068-2-6:2008, 20 g 10 Hz-2 kHz, 10 cycles		
Temperature range	-40° ... +85°C		
Weight	approx. 50 g		
EMC	DIN EN 61326-1:2013		

Order code

PTAM2	-	1	-	2	-	3	-	4	-	5	-	6
-------	---	----------	---	----------	---	----------	---	----------	---	----------	---	----------

Order example: PTAM2 – 1 – 60 – I1 – CW – T1.0 – M12A5

Accessories:

Connector cable (see page 15)



PTAM2 - Inclination sensor in MEMS technology
Version with analog output, tare function

Specifications

		Order options	
Number of axes of inclination	1 axis: Inclination in X axis 2 axes: Inclination in X and Y axes	1	1 2
Measurement range	1 axis: ±15 ... 180° (selectable in 15° increments) 2 axes: ±15 ... 60° (selectable in 15° increments)	2	15 ... 180 15 ... 60
Output	Voltage 0.5 ... 10 V, tare function Voltage 0.5 ... 4.5 V, tare function Current 4 ... 20 mA, 3 wire, tare function	3	U2/PMZ U8/PMZ I1/PMZ
Resolution	0.05°		
Linearity	±0.5°		
Mounting	Clamps, mounting plate		
Protection class	IP67/IP69 (connector output with IP69 connector)		
Signal characteristics	Signal increasing CW Signal increasing CCW	4	CW CCW
Output delay	0.1 s ... 10 s / 90%	5	Tx.x
Connection	Connector M12 axial, 5 pin Connector M12 radial, 5 pin Cable, standard length 2 m Deutsch connector, not shielded	6	M12A5 M12R5 KAB2M
Housing material	Aluminum		
Shock	DIN EN 60068-2-27:2010, 100 g/11 ms, 100 shocks		
Vibration	DIN EN 60068-2-6:2008, 20 g 10 Hz-2 kHz, 10 cycles		
Temperature range	-40° ... +85°C		
Weight	approx. 50 g		
EMC	DIN EN 61326-1:2013		

Order code

PTAM2	-	1	-	2	-	3	-	4	-	5	-	6
-------	---	----------	---	----------	---	----------	---	----------	---	----------	---	----------

Order example: PTAM2 – 1 – 60 – I1/PMZ – CW – T1.0 – M12A5

Accessories:

Connector cable (see page 16)

Dimensions

Connector M12, axial

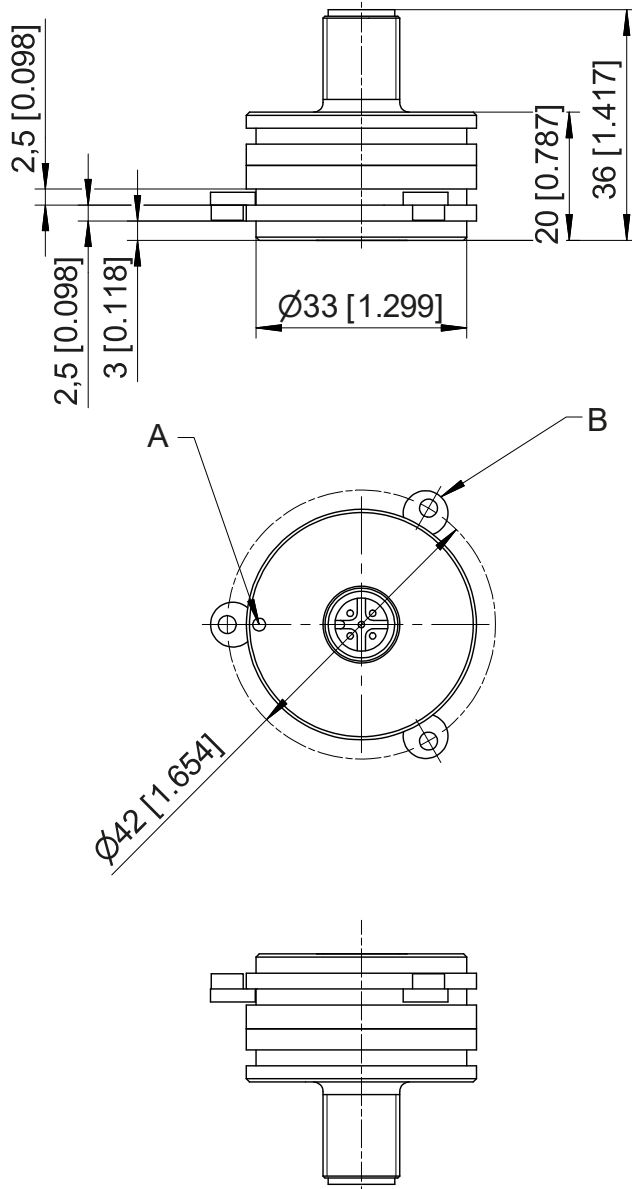

A – Marking

B – Mounting clamps PRPT-BFS1

Dimensions in mm [inch]. Weight approx. 50 g.

Dimensions informative only.

For guaranteed dimensions consult factory.

Connector M12, radial

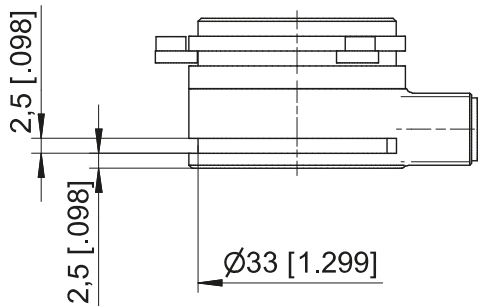
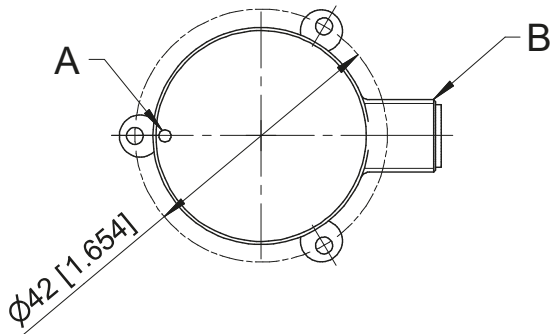
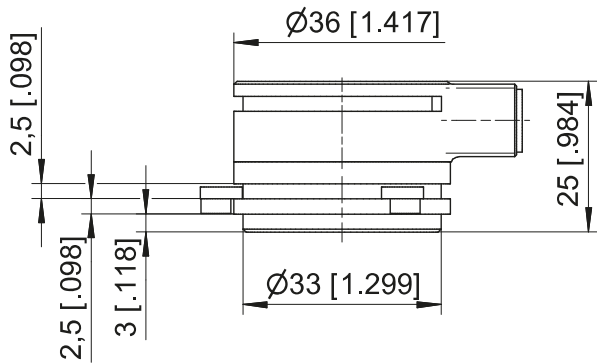

A – Marking
B – Connector M12

Dimensions in mm [inch]. Weight approx. 50 g.
Dimensions informative only.
For guaranteed dimensions consult factory.

Cable version

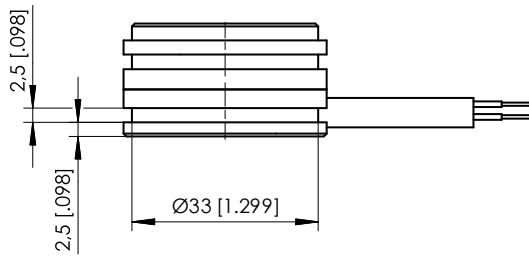
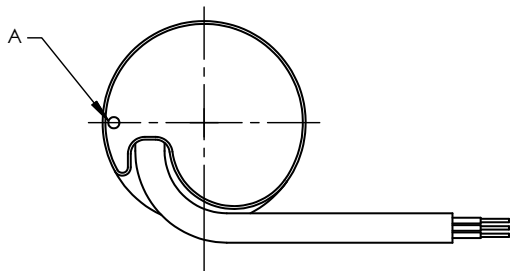
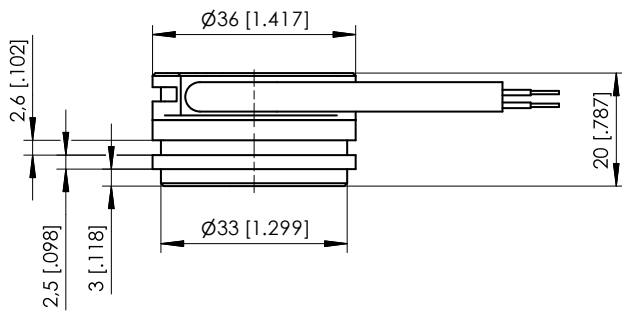

A – Marking

Dimensions in mm [inch].
Dimensions informative only.
For guaranteed dimensions consult factory.

Mounting possibilities PTxM2

Mounting possibilities of PTxM2 sensors

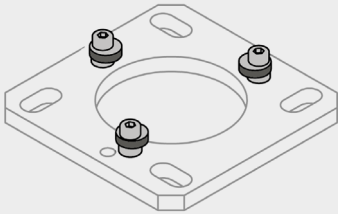

Mounting clamp BFS1

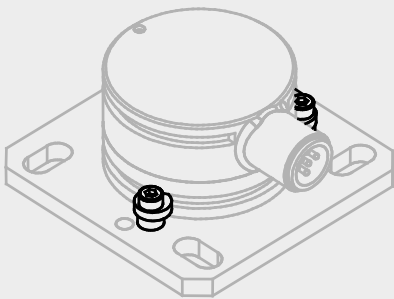

PRPT-BPL1 + PRPT-BFS1

(Mounting plates for screw mounting + mounting clamp)

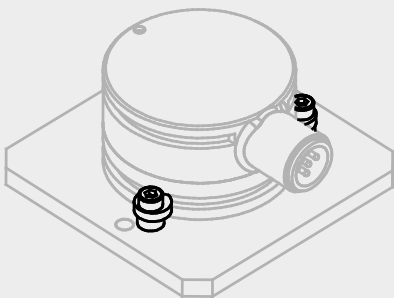

PRPT-BPL2 + PRPT-BFS1

(Mounting plates for welding assembly + mounting clamp)

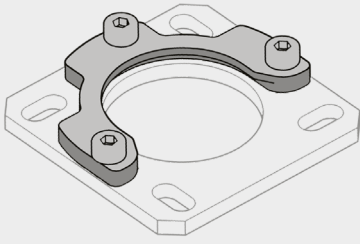

Mounting clamp BFS2

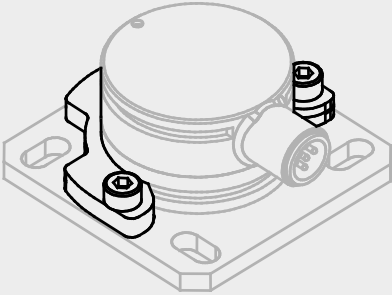

PRPT-BPL1 + PRPT-BFS2

(Mounting plates for screw mounting + mounting clamp)

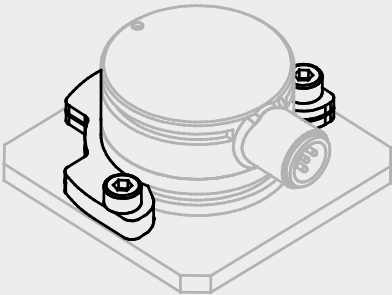

PRPT-BPL2 + PRPT-BFS2

(Mounting plates for welding assembly + mounting clamp)

PRPT-BPL1

(Screw mounting)

In combination with the mounting clamps PRPT-BFS1 (3 x M2.5) or in combination with the mounting bracket PRPT-BFS2 (3 x M4).

Dimensions in mm [inch].

Weight 30 g approx.

Dimensions informative only.

For guaranteed dimensions please consult factory.

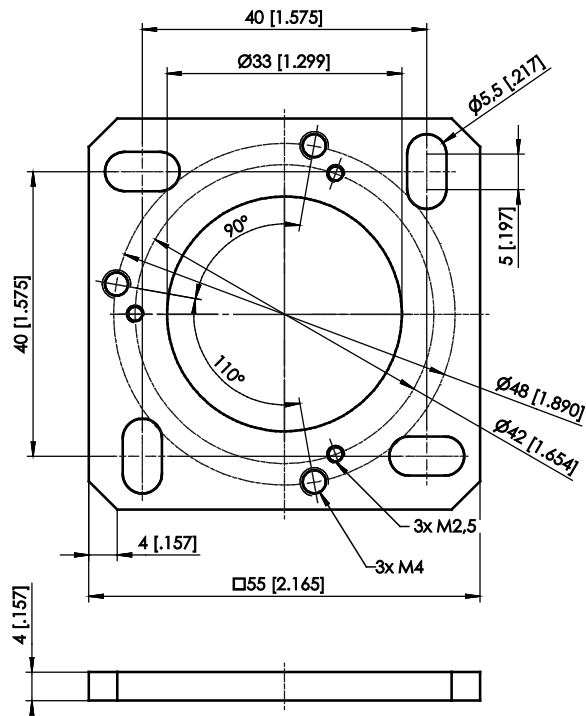

PRPT-BPL2

(Welding assembly)

In combination with the mounting clamps PRPT-BFS1 (3 x M2.5) or in combination with the mounting bracket PRPT-BFS2 (3 x M4).

Dimensions in mm [inch].

Weight 30 g approx.

Dimensions informative only.

For guaranteed dimensions please consult factory.

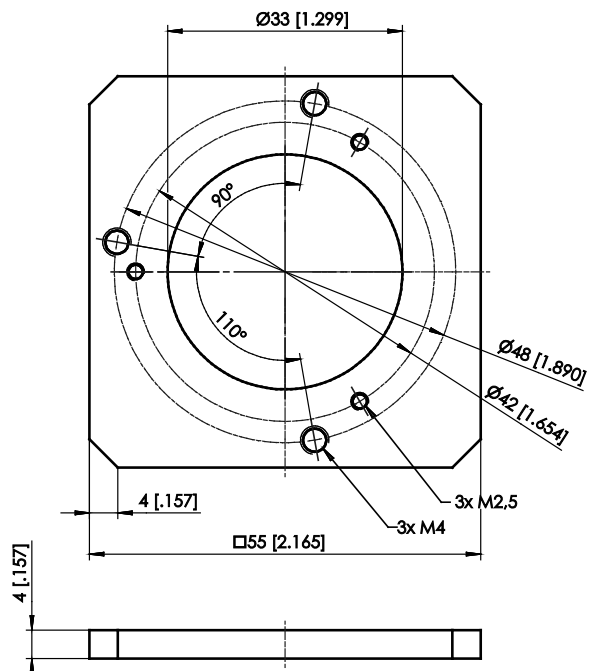

Output specification

Analog output

U2 Voltage output 0.5 ... 10 V 	Excitation voltage	18 ... 36 V DC
	Excitation current	typical 12 mA max. 16 mA
	Output voltage	0.5 ... 10 V DC
	Output current	2 mA max.
	Measuring rate	1 kHz standard
	Stability (temperature)	$\pm 100 \times 10^{-6} / ^\circ\text{C}$ f.s. (typical)
	Protection	Reverse polarity, short circuit
	Operating temperature	-40 ... +85 °C
	EMC	DIN EN 61326-1:2013

U8 Voltage output 0.5 ... 4,5 V 	Excitation voltage	18 ... 36 V DC
	Excitation current	typical 12 mA max. 16 mA
	Output voltage	0.5 ... 4,5 V DC
	Output current	2 mA max.
	Measuring rate	1 kHz standard
	Stability (temperature)	$\pm 100 \times 10^{-6} / ^\circ\text{C}$ f.s. (typical)
	Protection	Reverse polarity, short circuit
	Operating temperature	-40 ... +85 °C
	EMC	DIN EN 61326-1:2013

I1 Current output 4 ... 20 mA, 3 wires 	Excitation voltage	18 ... 36 V DC
	Excitation current	typical 32 mA max. 36 mA
	Load R _L	500 Ω max.
	Output current	4 ... 20 mA
	Measuring rate	1 kHz standard
	Stability (temperature)	$\pm 100 \times 10^{-6} / ^\circ\text{C}$ f.s. (typical)
	Protection	Reverse polarity, short circuit
	Operating temperature	-40 ... +85 °C
	EMC	DIN EN 61326-1:2013

Analog output (connector and cable output)

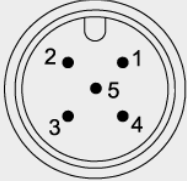
Signal wiring	Output signals	Connector pin no.	Cable color
1 axis Connector M12, 5 pin  View to the sensor connector	+U _B (excitation voltage)	1	brown
	Analog output X axis	2	white
	GND	3	blue
	Do not connect!	4	black
	Do not connect!	5	grey

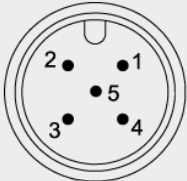
Signal wiring	Output signals	Connector pin no.	Cable color
2 axes Connector M12, 5 pin  View to the sensor connector	+U _B (excitation voltage)	1	brown
	Analog output X axis	2	white
	GND	3	blue
	Analog output Y axis	4	black
	Do not connect!	5	grey

Analog output, tare function

U2/PMZ Voltage output 0.5 ... 10 V 	Excitation voltage	18 ... 36 V DC
	Excitation current	typical 12 mA max. 16 mA
	Output voltage	0.5 ... 10 V DC
	Output current	2 mA max.
	Measuring rate	1 kHz standard
	Stability (temperature)	$\pm 100 \times 10^{-6}$ / °C f.s. (typical)
	Protection	Reverse polarity, short circuit
	Operating temperature	-40 ... +85 °C
	EMC	DIN EN 61326-1:2013

U8/PMZ Voltage output 0.5 ... 4,5 V 	Excitation voltage	18 ... 36 V DC
	Excitation current	typical 12 mA max. 16 mA
	Output voltage	0.5 ... 4,5 V DC
	Output current	2 mA max.
	Measuring rate	1 kHz standard
	Stability (temperature)	$\pm 100 \times 10^{-6}$ / °C f.s. (typical)
	Protection	Reverse polarity, short circuit
	Operating temperature	-40 ... +85 °C
	EMC	DIN EN 61326-1:2013

I1/PMZ Current output 4 ... 20 mA, 3 wires 	Excitation voltage	18 ... 36 V DC
	Excitation current	typical 32 mA max. 36 mA
	Load R_L	500 Ω max.
	Output current	4 ... 20 mA
	Measuring rate	1 kHz standard
	Stability (temperature)	$\pm 100 \times 10^{-6}$ / °C f.s. (typical)
	Protection	Reverse polarity, short circuit
	Operating temperature	-40 ... +85 °C
	EMC	DIN EN 61326-1:2013

Analog output, tare function (connector and cable output)

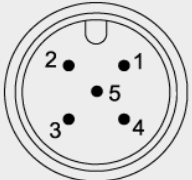
Signal wiring	Output signals	Connector pin no.	Cable color
1 axis Connector M12, 5 pin  View to the sensor connector	Excitation voltage +U _B	1	brown
	Analog output X	2	white
	GND	3	blue
	Do not connect!	4	black
	ZERO	5	grey

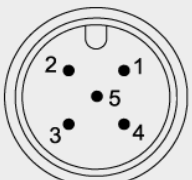
Signal wiring	Output signals	Connector pin no.	Cable color
2 axes Connector M12, 5 pin  View to the sensor connector	Excitation voltage +U _B	1	brown
	Analog output X	2	white
	GND	3	blue
	Analog output Y	4	black
	ZERO	5	grey

Tare function ZERO (PMZ)

Programming the zero point by the customer:

The tare function "ZERO" allows to program the zero point of the output range by using a signal ZERO available at the connector. This Signal ZERO must be connected with GND via a push button. At first the sensor must be brought into the zero position. Pushing the button for 2 seconds sets the actual position as the zero point. The values are available as well after switching off the sensor.

Position of the inclination axis and characteristic of the linear output PTxM2

PTxM2 axial

Connector M12, 1 axis
A – Marking

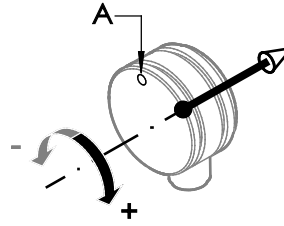

PTxM2 axial

Connector M12, 2 axes
A – Marking

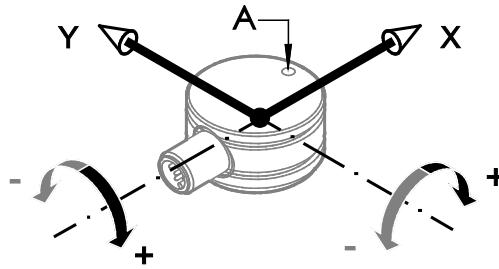

PTxM2 radial

Connector M12, 1 axis
A – Marking

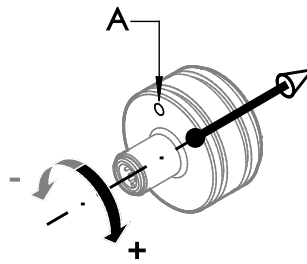

PTxM2 radial

Connector M12, 2 axes
A – Marking

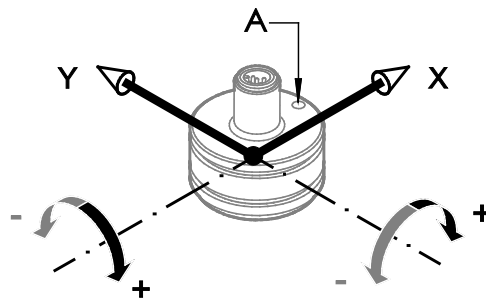

Output signal

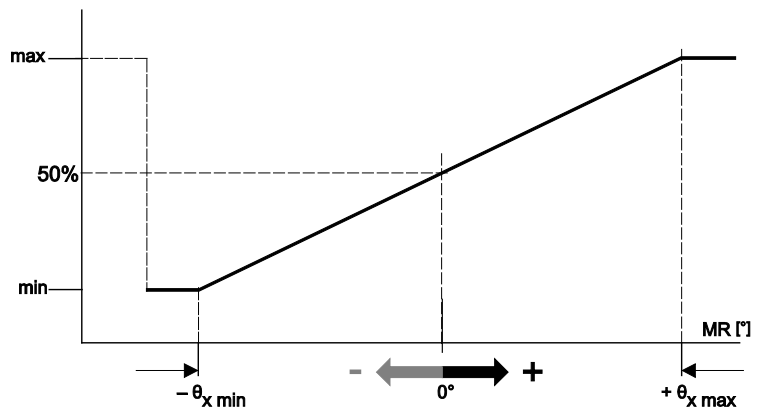

Accessories

Connector cable M12, 4 pin (angular coupling)

shielded connector
Suitable for 5-pin
sensor connectors

The 4-core screened cable is supplied with a mating 4-pin 90° M12 connector at one end and 4 wires at the other end. Available lengths are 2 m, 5 m and 10 m.
Wire: cross sectional area 0.34 mm²
Cable diameter: 5.6 ±0.2 mm

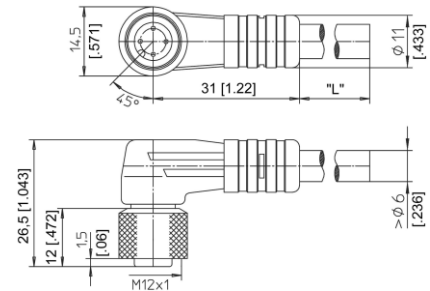

Order code

KAB - xM - M12/4F/W - LITZE

IP69: **KAB - xM - M12/4F/W/69K - LITZE**

xM = length in m

Connector cable M12, 4 pin (straight coupling)

shielded connector
Suitable for 5-pin
sensor connectors

The 4-core screened cable is supplied with a mating 4-pin M12 connector at one end and 4 wires at the other end. Available lengths are 2 m, 5 m and 10 m.
Wire: cross sectional area 0.34 mm²
Cable diameter: 5.6 ±0.2 mm

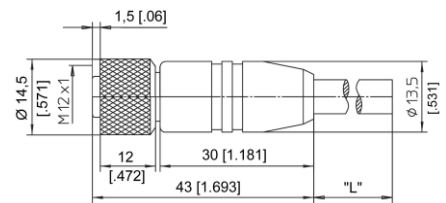

Order code

KAB - xM - M12/4F/G - LITZE

IP69: **KAB - xM - M12/4F/G/69K - LITZE**

xM = length in m

Signal wiring	Plug connection / cable color			
	M12, 4 pin	1 brown	2 white	3 blue

Applicable for cable carriers

Maximum movement speed	3 m/s
Maximum acceleration	5 m/s ²
Minimum bending radius	10 x cable diameter

Connector cable M12, 5 pin (angular coupling)

shielded connector

The 5-core screened cable is supplied with a mating 5-pin 90° M12 connector at one end and 4 wires at the other end. Available lengths are 2 m, 5 m and 10 m.

Wire: cross sectional area 0.34 mm²

Cable diameter: 5.6 ±0.2 mm

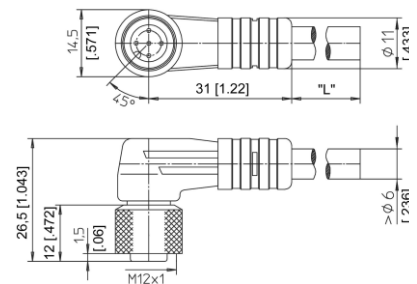

Order code

KAB - xM - M12/5F/W - LITZE

IP69: **KAB - xM - M12/5F/W/69K - LITZE**

xM = length in m

Connector cable M12, 5 pin (straight coupling)

shielded connector

The 5-core screened cable is supplied with a mating 5-pin M12 connector at one end and 4 wires at the other end. Available lengths are 2 m, 5 m and 10 m.

Wire: cross sectional area 0.34 mm²

Cable diameter: 5.6 ±0.2 mm

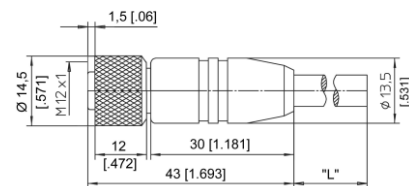

Order code

KAB - xM - M12/5F/G - LITZE

IP69: **KAB - xM - M12/5F/G/69K - LITZE**

xM = length in m

Signal wiring M12, 5 pin	Plug connection / Cable color				
	1	2	3	4	5
	brown	white	blue	black	grey

Applicable for cable carriers

Maximum movement speed	3 m/s
Maximum acceleration	5 m/s ²
Minimum bending radius	10 x cable diameter