

 PRDS6

Angle sensor for heavy duty applications



- Measurement range 0°... 360°
- Protection class IP67/IP69
- Hermetically sealed stainless steel housing
- Longitudinal water barrier; potted electronics
- Contactless with external position magnet, wear-free

Product versions



Incremental output



Digital output SSI



Digital output CANopen/SAE J1939
(optional redundant)

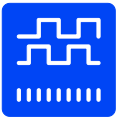

PRDS6 - Magnetic Angle Sensor
Version with incremental output

Specifications

		Order options	
Mechanical connection	Contactless with external position magnet	1	K
Measurement range	0 ... 360°		
Resolution	1, 2, 3 ... 1024 pulses per revolution	2	1, 2, 3 ... 1024
Linearity	±1% (typical)		
Output	Incremental encoder output RS422 compatible output with excitation 5 V DC Incremental encoder output RS422 compatible output with excitation 8 ... 36 V Incremental encoder output HTL compatible output with excitation 8 ... 36 V	3	RS5VF RS24VF HT24VF
Rated distance sensor / magnet	Depending on the position magnet		
Connection	8-pin connector M12, axial 8-pin connector M12, radial Cable, standard length 2 m Deutsch connector, not shielded	4	M12A8 M12R8 KAB2M
Housing material	Stainless steel EN 1.4404 (AISI 316L)	5	VA
Mounting	Screws M6		
Protection class	IP67/IP69		
Shock	DIN EN 60068-2-27:2010, 100 g/11 ms, 100 shocks		
Vibration	DIN EN 60068-2-6:2008, 20 g 10 Hz-2 kHz, 10 cycles		
Temperature range	-40 ... +85°C		
Weight	390 g approx. (without cable)		
EMC	DIN EN 61326-1:2013		

Order code

PRDS6 – **1** – **2** – **3** – **4** – **5**

Order example: PRDS6 – K – 1024 – RS24VF – M12A8 – VA

Accessories:

Connector cable (see page 22)

Position magnets (see from page 8)



PRDS6 - Magnetic Angle Sensor
Version with digital output SSI

Specifications

			Order options
Mechanical connection	Contactless with external position magnet	1	K
Measurement range	0 ... 360°		
Output	Synchronous serial output with excitation 5 V DC Synchronous serial output with excitation 10 ... 36 V	2	RSSI5V RSSI24V
Code characteristics	Signal increasing CW, clockwise Signal increasing CCW, counterclockwise	3	CW CCW
Resolution	12 Bit (4096 steps) per revolution		
Repeatability	±0.1° (typical)		
Linearity	±1% (typical)		
Rated distance sensor / magnet	Depending on the position magnet		
Connection	8-pin connector M12, axial 8-pin connector M12, radial Cable, standard length 2 m Deutsch connector, not shielded	4	M12A8 M12R8 KAB2M
Housing material	Stainless steel EN 1.4404 (AISI 316L)	5	VA
Mounting	Screws M6		
Protection class	IP67/IP69		
Shock	DIN EN 60068-2-27:2010, 100 g/11 ms, 100 shocks		
Vibration	DIN EN 60068-2-6:2008, 20 g 10 Hz-2 kHz, 10 cycles		
Temperature range	-40 ... +85°C		
Weight	390 g approx. (without cable)		
EMC	DIN EN 61326-1:2013		

Order code

PRDS6 – 1 – 2 – 3 – 4 – 5

Order example: PRDS6 – K – RSSI5V – CW – M12A8 – VA

Accessories:

Connector cable (see page 22)

Position magnets (see from page 8)



PRDS6 - Magnetic Angle Sensor
Version with digital output CANopen/SAE J1939
(optional redundant)

Specifications

		Order options
Mechanical connection	Contactless with external position magnet	1 K
Measurement range	0 ... 360°	
Output	CANopen CAN SAE J1939 CANopen, redundant CAN SAE J1939, redundant	2 CANOP CANJ1939 CANOPR CANJ1939R
Resolution	0.05° max.	
Linearity	±1% (typical)	
Rated distance sensor / magnet	Depending on the position magnet	
Connection	5-pin connector M12 axial 5-pin connector M12 radial Deutsch connector, not shielded	3 M12A5/CAN M12R5/CAN
Housing material	Stainless steel EN 1.4404 (AISI 316L)	4 VA
Mounting	Screws M6	
Protection class	IP67/IP69	
Shock	DIN EN 60068-2-27:2010, 100 g/11 ms, 100 shocks	
Vibration	DIN EN 60068-2-6:2008, 20 g 10 Hz-2 kHz, 10 cycles	
Temperature range	-40 ... +85°C	
Weight	390 g approx. (without cable)	
EMC	DIN EN 61326-1:2013	

Order code

PRDS6 – **1** – **2** – **3** – **4**

Order example: PRDS6 – K – CANOP – M12A5/CAN – VA

Accessories:

Connector cable (see page 23)

Position magnets (see from page 8)

Dimensions

Connector M12, axial

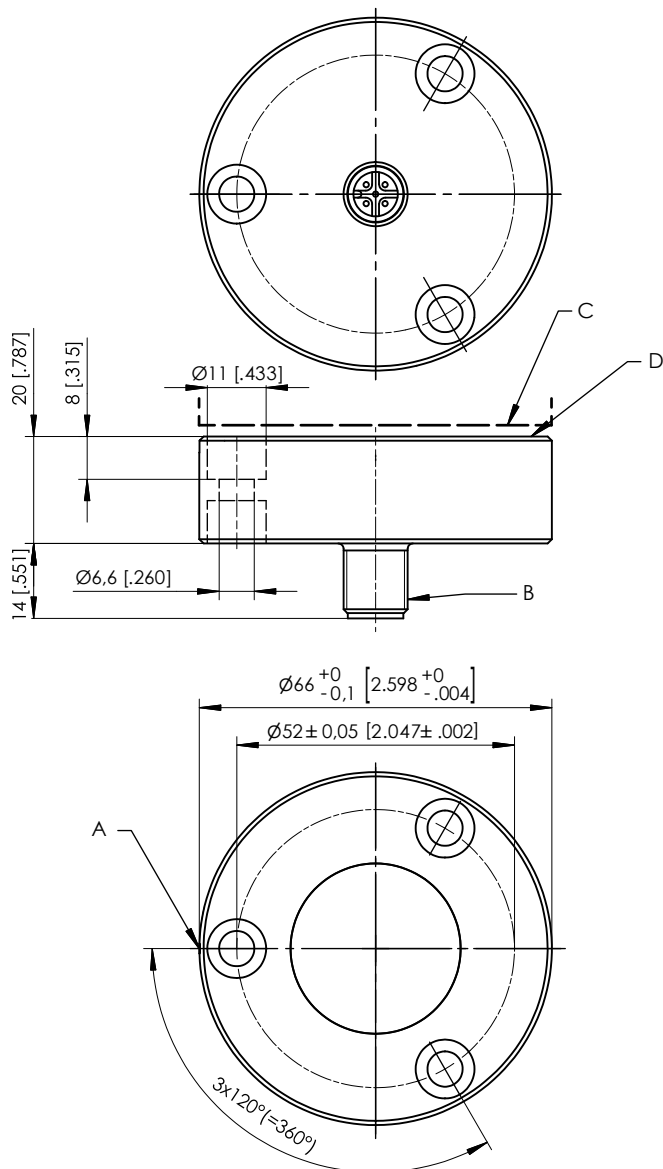

- A – Marking
- B – Connector M12
- C – Position magnet
- D – Measurement area

Dimensions in mm [inch].
Dimensions informative only.
For guaranteed dimensions consult factory.

Connector M12, radial

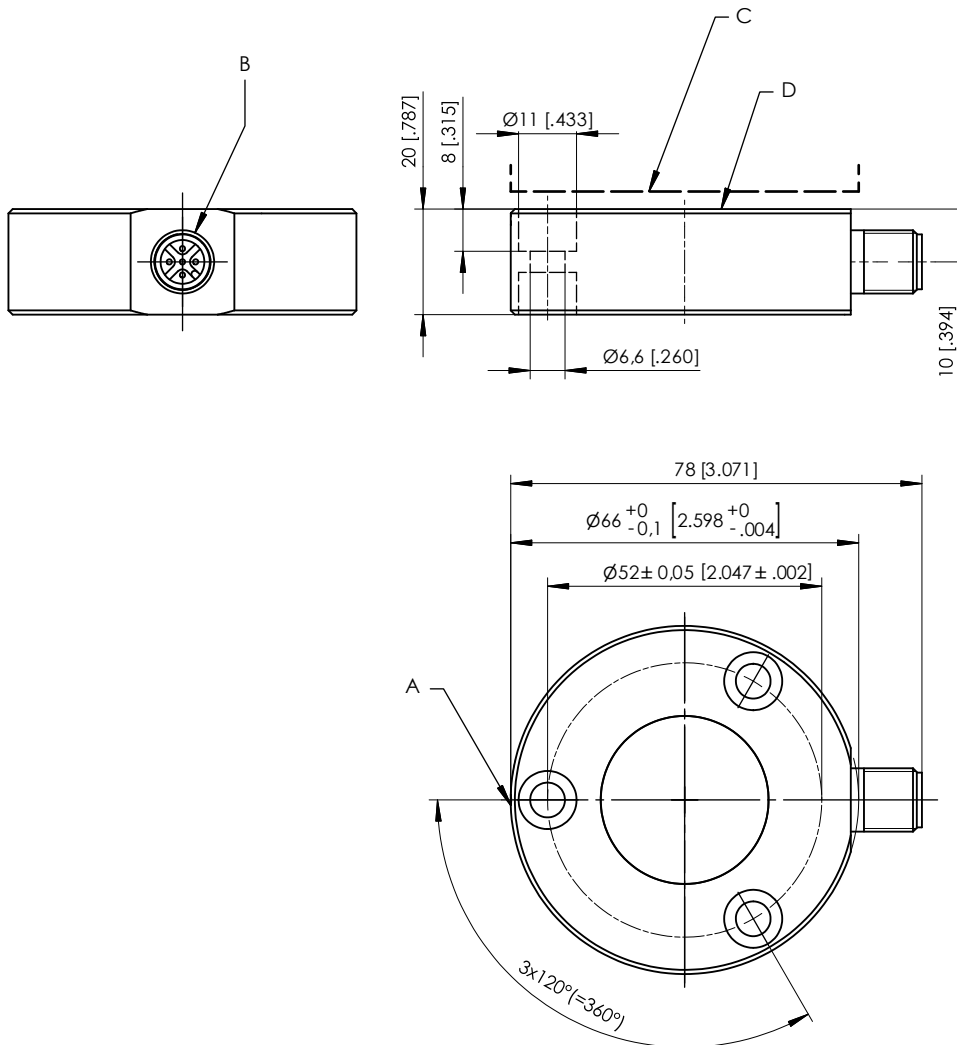

- A – Marking
- B – Connector M12
- C – Position magnet
- D – Measurement area

Dimensions in mm [inch].
Dimensions informative only.
For guaranteed dimensions consult factory.

Cable version

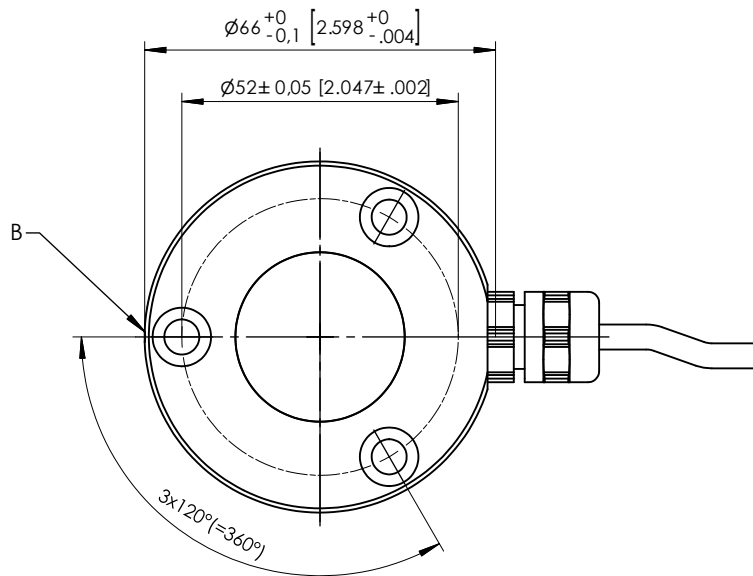
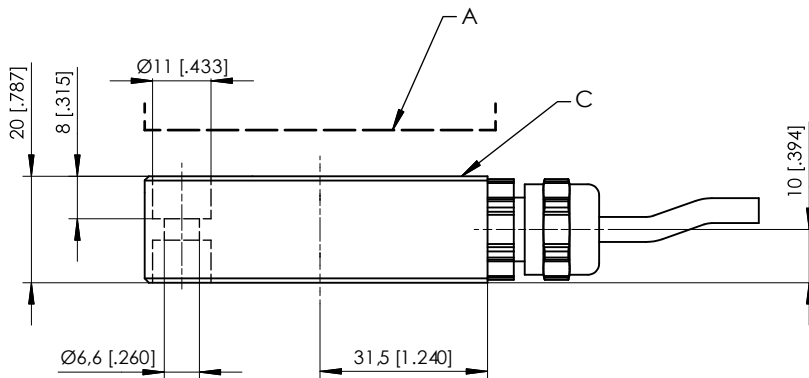

- A – Position magnet
- B – Marking
- C – Measurement area

Dimensions in mm [inch].
Dimensions informative only.
For guaranteed dimensions consult factory.

Position magnets

PRMAG20

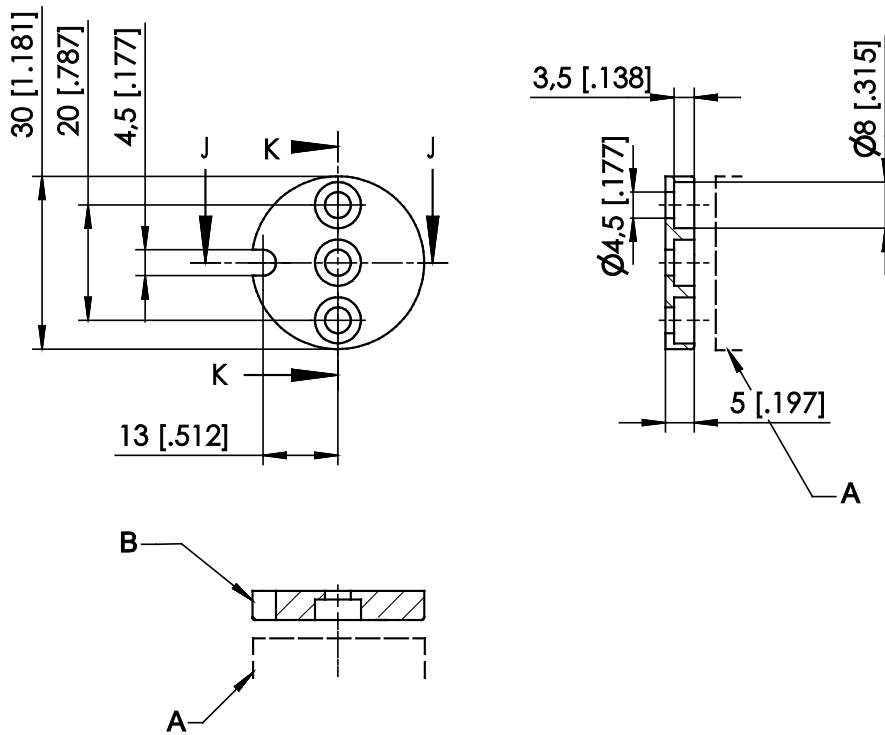

A – Sensor
B – Marking

Order code	Weight	Material	Moment of inertia
PRMAG20	approx. 12 g	zinc coated steel, plastic	1.3 kgmm ²

A misalignment of the position magnet has an effect on the linearity.

Dimensions in mm [inch].

Dimensions informative only.

For guaranteed dimensions please consult factory.

PRMAG21

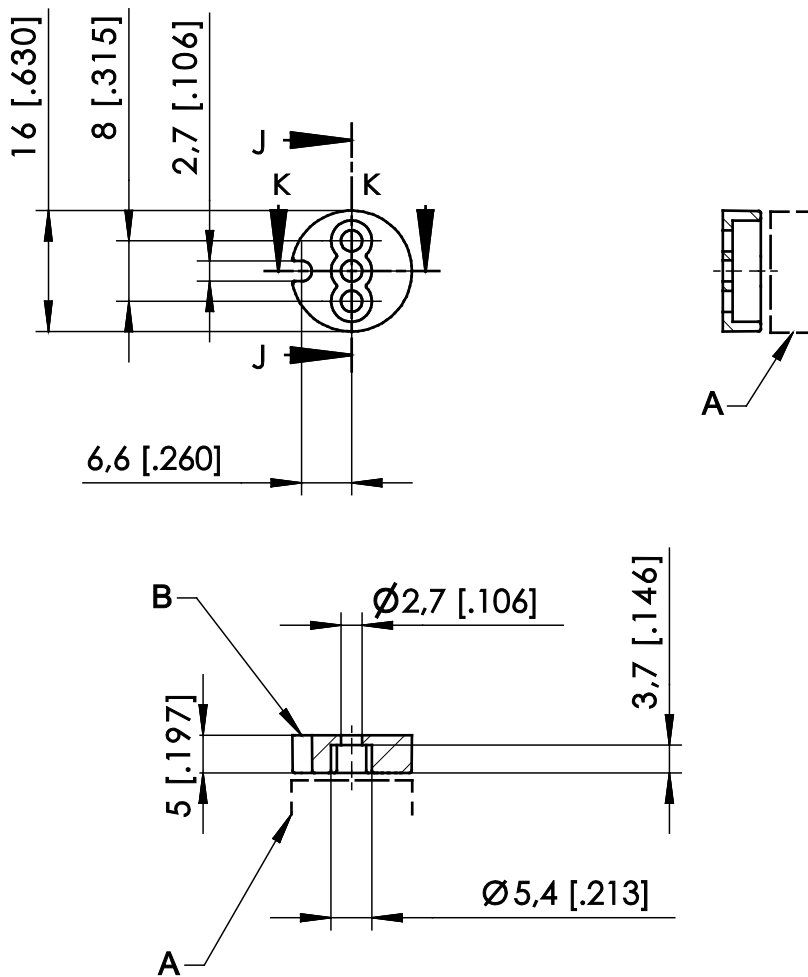

A – Sensor
B – Marking

Order code	Weight	Material	Moment of inertia
PRMAG21	approx. 3 g	zinc coated steel; plastic	0.1 kgmm ²

A misalignment of the position magnet has an effect on the linearity.

Dimensions in mm [inch]

Dimensions informative only.

For guaranteed dimensions please consult factory.

PRMAG22

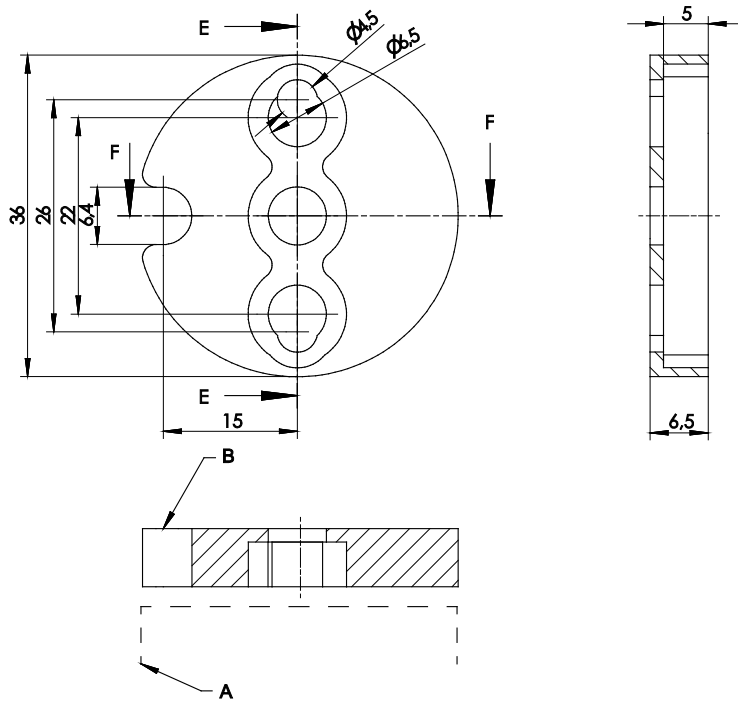

A – Sensor
B – Marking

Order code	Weight	Material	Moment of inertia
PRMAG22	approx. 19 g	zinc coated steel, plastic	3 kgmm ²

A misalignment of the position magnet has an effect on the linearity.

Dimensions in mm [inch].

Dimensions informative only

For guaranteed dimensions please consult factory.

PRMAG6-Z / PRMAG6-Z-VA

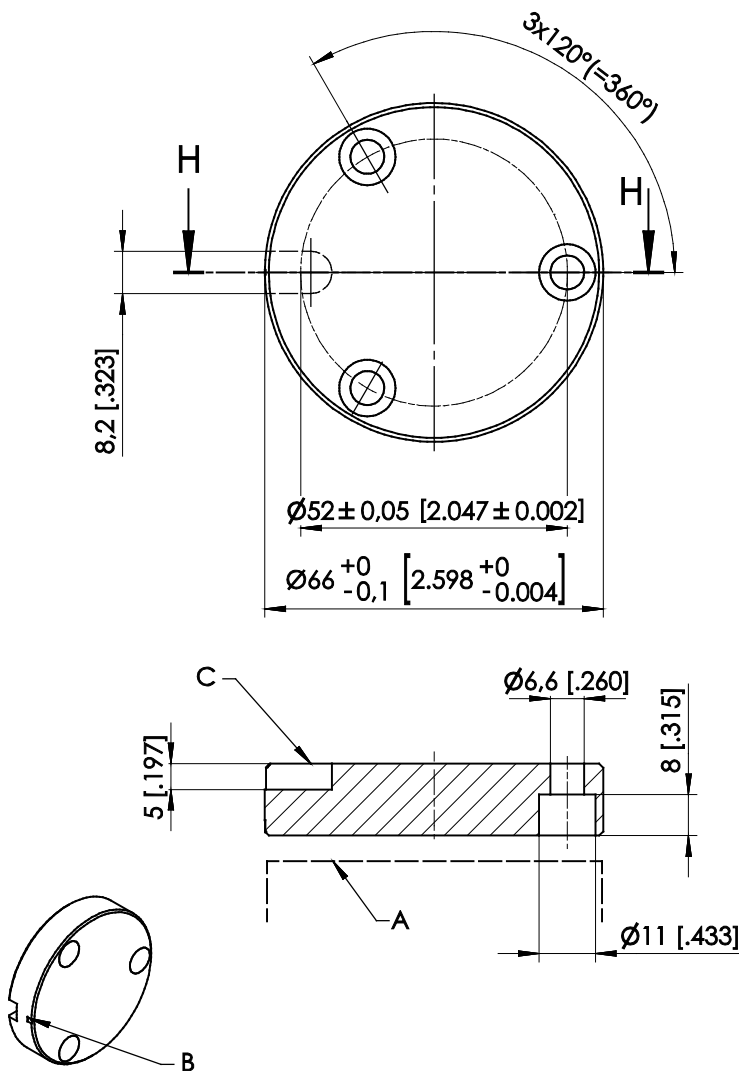

- A – Sensor
- B – Marking
- C – Notch

Order code	Weight	Material	Moment of inertia
PRMAG6-Z	approx. 110 g	AlMgSi1,	65 kgmm ²
PRMAG6-Z-VA	approx. 315 g	stainless steel EN 1.4404 (AISI 316L)	190 kgmm ²

A misalignment of the position magnet has an effect on the linearity.

Dimensions in mm [inch].

Dimensions informative only.

For guaranteed dimensions please consult factory.

Measuring error by misalignment of the position magnet

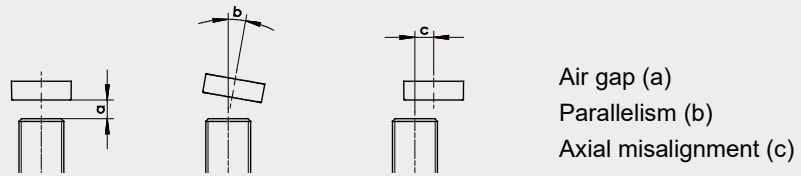

Sensor	Position magnet	Air gap [mm]	Parallelism [°]	Error by axial misalignment [°]					
				0.2 mm	0.5 mm	1 mm	2 mm	3 mm	4 mm
PRAS6	PRMAG20	0 ... 5.5	0 ... 5	0.15	0.4	0.8	2.2	5	–
PRDS6	PRMAG21	0 ... 3	0 ... 5	0.2	0.4	1	3.8	10	–
	PRMAG22	0 ... 8.5	0 ... 5	0.1	0.4	1	2.2	4.5	8
	PRMAG6-Z-(VA)	0 ... 7.5	0 ... 5	0.1	0.2	0.6	1.5	4.5	8.5

Output specification

Incremental output

RS5VF /RS24VF Incremental 	Interface	EIA RS-422
	Excitation voltage	RS5VF: 5 V DC $\pm 10\%$ RS24VF: 8 ... 36 V DC
	Excitation current	100 mA max., depending on the load
	Max. pulse frequency	500 kHz
	Output signals	A, \bar{A} , B, \bar{B} , Z, \bar{Z} Push-Pull
	Output current	10 mA max.
	Stability (temperature)	$\pm 50 \times 10^{-6}$ / °C f.s. (typical)
	Operating temperature	-40 ... +85 °C
	Protection	Short circuit
	EMC	DIN EN 61326-1:2013

Output signals

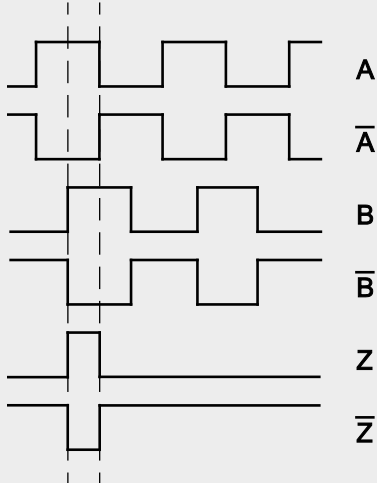

Pulse sequence for clockwise rotation CW in view of shaft or active front of sensor.
A zero impulse Z, \bar{Z} is generated at the reference position.

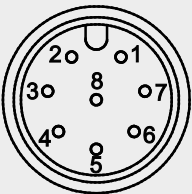
Signal wiring	Output signals	Connector pin no.	Cable color
Connector M12, 8 pin  View to the sensor connector	Excitation +	1	white
	Excitation GND	2	brown
	A	4	yellow
	\bar{A}	6	pink
	B	3	green
	\bar{B}	5	grey
	Z	7	blue
	\bar{Z}	8	red

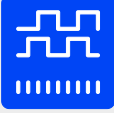
HT24VF Incremental 	Interface	HTL
	Excitation voltage	8 ... 36 V DC
	Excitation current	100 mA max., depending on the load
	Max. pulse frequency	500 kHz
	Output signals	A, \bar{A} , B, \bar{B} , Z, \bar{Z} Push-Pull
	Output current	10 mA max.
	Stability (temperature)	$\pm 50 \times 10^{-6}$ / °C f.s. (typical)
	Operating temperature	-40 ... +85 °C
	Protection	Short circuit
	EMC	DIN EN 61326-1:2013

Output signals

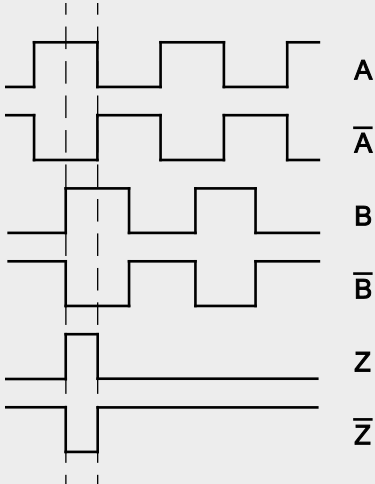

Pulse sequence for clockwise rotation CW in view of shaft or active front of sensor.
A zero impulse Z, \bar{Z} is generated at the reference position.

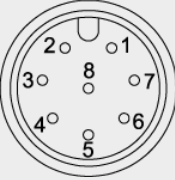
Signal wiring	Output signals	Connector pin no.	Cable color
Connector M12, 8 pin  View to the sensor connector	Excitation +	1	white
	Excitation GND	2	brown
	A	4	yellow
	\bar{A}	6	pink
	B	3	green
	\bar{B}	5	grey
	Z	7	blue
	\bar{Z}	8	red

SSI output

RSSI5V/RSSI24V Synchronous serial SSI 	Interface	EIA RS-422
	Excitation voltage	RSSI5V: 5 V DC ±10% RSSI24V: 10 ... 36 V DC
	Excitation current	100 mA max. without load
	Clock frequency	100 kHz ... 500 kHz
	Code	Gray-Code, continuous progression, 12 bit
	Delay between pulse trains	20 µs min.
	Stability (temperature)	±50 x 10 ⁻⁶ / °C f.s. (typical)
	Operating temperature	Refer to sensor specifications
	Protection	Short circuit
	EMC	EN 61326-1:2013

Data format

(Train of 13 pulses)

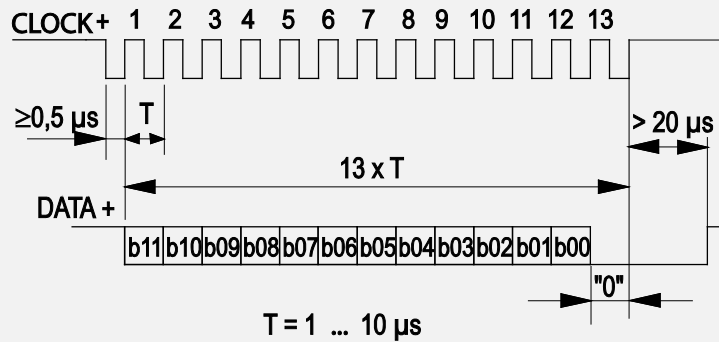

Transmission rate	Cable length	Baud rate	Note:
	50 m	100 - 1000 kHz	Extension of the cable length will reduce the maximum transmission rate. The signals <u>CLOCK</u> / <u>CLOCK</u> and <u>DATA</u> / <u>DATA</u> must be connected in a twisted pair cable, shielded in pairs, the pairs also commonly shielded.
	100 m	100 - 300 kHz	

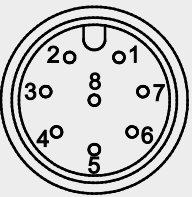
Signal wiring	Output signals	Connector pin no.	Cable color
Connector M12, 8 pin  View to the sensor connector	Excitation +	1	white
	Excitation GND	2	brown
	CLOCK	3	green
	<u>CLOCK</u>	4	yellow
	DATA	5	grey
	<u>DATA</u>	6	pink
	-	7	blue
	-	8	red

Digital output CANopen

CANOP CANopen 	CAN Specification	ISO 11898, Basic and Full CAN 2.0 B
	Communication profile	CANopen CiA 301 V 4.02, Slave
	Device profile	Encoder CiA 406 V 3.2
	Configuration services	Layer Setting Service (LSS), CiA Draft Standard 305 (transmission rate, node id)
	Error Control	Node Guarding, Heartbeat, Emergency Message
	Node ID	Default: 127; programmable via LSS or SDO
	PDO	3 TxPDO, 0 RxPDO, static mapping
	PDO Modes	Event-/Time triggered, Remote-request, Sync cyclic/acyclic
	SDO	1 server, 0 Client
	CAM	8 cams
	Certified	Yes
	Transmission rates	50 kBaud to 1 MBaud, default: 125 kBaud; programmable via LSS or SDO
	Bus connection	M12 connector, 5 pin
	Integrated bus terminating resistor	Adjustable by the customer
	Bus, galvanic isolated	No

Specifications	Excitation voltage	8 ... 36 V DC
	Excitation current	20 mA typical at 24 V DC 40 mA typical at 12 V DC, 80 mA max.
	Resolution	0.05° max.
	Stability (temperature)	$\pm 50 \times 10^{-6}/^{\circ}\text{C}$ f.s. (typical)
	Repeatability	1 LSB
	Operating temperature	See specification of the respective sensor
	Protection	Reverse polarity, short circuit
	Dielectric strength	1 kV (V AC, 50 Hz, 1 min.)
	EMC	DIN EN 61326-1:2013

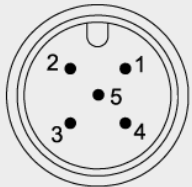
Signal wiring	Output signals	Connector pin no.	Cable color
Connector M12, 5 pin 	Shield	1	brown
	Excitation +	2	white
	GND	3	blue
	CAN-H	4	black
	CAN-L	5	grey

View to the sensor connector

CANOPR CANopen 	CAN Specification	ISO 11898, Basic and Full CAN 2.0 B
	Communication profile	CANopen CiA 301 V 4.02, Slave
	Device profile	Encoder CiA 406 V 3.2
	Configuration services	Layer Setting Service (LSS), CiA Draft Standard 305 (transmission rate, node id)
	Error Control	Node Guarding, Heartbeat, Emergency Message
	Node ID	Default: 127 and 126; programmable via LSS or SDO
	PDO	3 TxPDO, 0 RxPDO, static mapping
	PDO Modes	Event-/Time triggered, Remote-request, Sync cyclic/acyclic
	SDO	1 server, 0 Client
	CAM	8 cams
	Certified	Yes
	Transmission rates	50 kBaud to 1 MBaud, default: 125 kBaud; programmable via LSS or SDO
	Bus connection	M12 connector, 5 pin
	Integrated bus terminating resistor	adjustable by the customer
	Bus, galvanic isolated	No

Specifications	Excitation voltage	8 ... 36 V DC
	Excitation current	40 mA typical at 24 V DC 80 mA typical at 12 V DC, 120 mA max.
	Measuring rate	1 kHz (asynchronous)
	Stability (temperature)	$\pm 50 \times 10^{-6}/^{\circ}\text{C}$ f.s. (typical)
	Repeatability	1 LSB
	Operating temperature	See specification of the respective sensor
	Protection	Reverse polarity, short circuit
	Dielectric strength	1 kV (V AC, 50 Hz, 1 min.)
	EMC	DIN EN 61326-1:2013

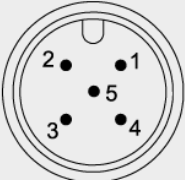
Signal wiring	Output signals	Connector pin no.	Cable color
Connector M12, 5 pin  <p>View to the sensor connector</p>	Shield	1	brown
	Excitation +	2	white
	GND	3	blue
	CAN-H	4	black
	CAN-L	5	grey

Digital output CAN SAE J1939

CANJ1939 SAE J1939 	CAN Specification	ISO 11898, Basic and Full CAN 2.0 B
	Transceiver	24V-compliant, not isolated
	Communication profile	SAE J1939
	Baud Rate	250 kbit/s
	Internal termination resistor	adjustable by the customer
	Address	Default 247d, configurable

NAME Fields	Arbitrary address capable	1	Yes
	Industry group	0	Global
	Vehicle system	7Fh (127d)	Non specific
	Vehicle system instance	0	
	Function	FFh (255d)	Non specific
	Function instance	0	
	ECU instance	0	
	Manufacturer	145h (325d)	Manufacturer ID
	Identity number	0nnn	Serial number 21 bit

Parameter Group Numbers (PGN)	Configuration data	PGN EF00h	Proprietary-A (PDU1 peer-to-peer)
	Process data	PGN FFnnh	Proprietary-B (PDU2 broadcast); nn Group Extension (PS) configurable

Specifications	Excitation voltage	8 ... 36 V DC
	Excitation current	20 mA typical at 24 V DC 40 mA typical at 12 V DC 80 mA max.
	Measuring rate	1 kHz (asynchronous)
	Stability (temperature)	$\pm 50 \times 10^{-6}/^{\circ}\text{C}$ f.s. (typical)
	Repeatability	1 LSB
	Operating temperature	See specification of the respective sensor
	Protection	Reverse polarity, short circuit
	Dielectric strength	1 kV (V AC, 50 Hz, 1 min.)
	EMV	DIN EN 61326-1:2013

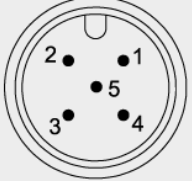
Signal wiring	Output signals	Connector pin no.	Cable color
Connector M12, 5 pin  View to the sensor connector	Shield	1	brown
	Excitation +	2	white
	GND	3	blue
	CAN-H	4	black
	CAN-L	5	grey

CANJ1939R CAN SAE J1939 	CAN Specification	ISO 11898, Basic and Full CAN 2.0 B
	Transceiver	24V-compliant, not isolated
	Communication profile	SAE J1939
	Baud Rate	250 kbit/s
	Internal termination resistor	Adjustable by the customer
	Address	Default 247d and 246d, configurable

NAME Fields	Arbitrary address capable	1	Yes
	Industry group	0	Global
	Vehicle system	7Fh (127d)	Non specific
	Vehicle system instance	0	
	Function	FFh (255d)	Non specific
	Function instance	0	
	ECU instance	0	
	Manufacturer	145h (325d)	Manufacturer ID
	Identity number	0nnn	Serial number 21 bit

Parameter Group Numbers (PGN)	Configuration data	PGN EF00h	Proprietary-A (PDU1 peer-to-peer)
	Process data	PGN FFnnh	Proprietary-B (PDU2 broadcast); nn Group Extension (PS) configurable

Specifications	Excitation voltage	8 ... 36 V DC
	Excitation current	40 mA typical at 24 V DC 80 mA typical at 12 V DC 120 mA max.
	Measuring rate	1 kHz (asynchronous)
	Stability (temperature)	$\pm 50 \times 10^{-6}/^{\circ}\text{C}$ f.s. (typical)
	Repeatability	1 LSB
	Operating temperature	See specification of the respective sensor
	Protection	Reverse polarity, short circuit
	Dielectric strength	1 kV (V AC, 50 Hz, 1 min.)
	EMV	DIN EN 61326-1:2013

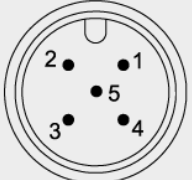
Signal wiring	Output signals	Connector pin no.	Cable color
Connector M12, 5 pin  View to the sensor connector	Shield	1	brown
	Excitation +	2	white
	GND	3	blue
	CAN-H	4	black
	CAN-L	5	grey

Accessories

Connector cable M12, 8 pin (angular coupling)

shielded connector

The 8-lead shielded cable is supplied with a mating 8-pin 90° M12 connector at one end and 8 wires at the other end. Available lengths are 2 m, 5 m and 10 m.
Wire: cross sectional area 0.25 mm²
Cable diameter: 6.3 ±0.2 mm

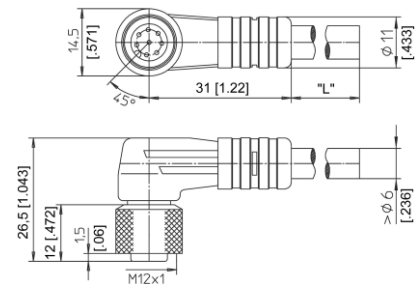

Order code

KAB - xM - M12/8F/W - LITZE

IP69: **KAB - xM - M12/8F/W/69K - LITZE**

xM = length in m

Connector cable M12, 8 pin (straight coupling)

shielded connector

The 8-lead shielded cable is supplied with a mating 8-pin M12 connector at one end and 8 wires at the other end. Available lengths are 2 m, 5 m and 10 m.
Wire: cross sectional area 0.25 mm²
Cable diameter: 6.3 ±0.2 mm

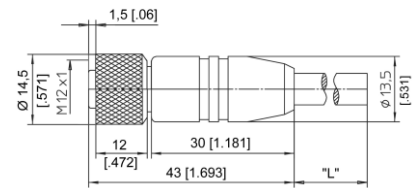

Order code

KAB - xM - M12/8F/G - LITZE

IP69: **KAB - xM - M12/8F/G/69K - LITZE**

xM = length in m

Signal wiring M12, 8 pin	Plug connection / cable color							
	1	2	3	4	5	6	7	8
	white	brown	green	yellow	grey	pink	blue	red

Applicable for cable carriers

Maximum movement speed	3 m/s
Maximum acceleration	5 m/s ²
Minimum bending radius	10 x cable diameter

Connector/bus cable M12, 5 pin CAN-Bus

The 5-lead shielded cable is supplied with a female 5 pin M12 connector at one end and a male 5 pin M12 connector at the other end.

Available lengths are 0.3 m, 2 m, 5 and 10 m.

Cable diameter: 6.7 ±0.2 mm

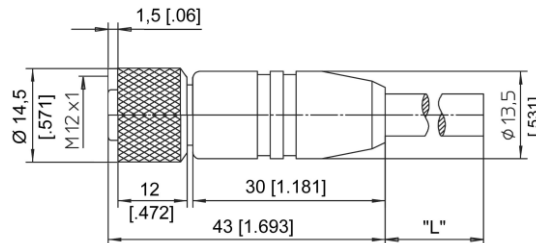

Order code

KAB - xM - M12/5F/G - M12/5M/G - CAN

IP69: **KAB - xM - M12/5F/G/69K - M12/5M/G/69K - CAN**

xM = length in m

Applicable for cable carriers

Maximum movement speed	3 m/s
Maximum acceleration	5 m/s ²
Minimum bending radius	10 x cable diameter

T-connector for bus cable M12, 5 pin CAN-Bus

Order code

KAB - TCONN - M12/5M - 2M12/5F - CAN



Terminating resistor M12, 5 pin CAN-Bus

Order code

KAB - RTERM - M12/5M/G - CAN

