

 PRAS3

Angle sensor for standard industrial applications



- Measurement range 0°... 360°
- Protection class IP67/IP69
- Measurement with 10 mm shaft or 6 mm hollow shaft
- Optional redundant second channel

Product versions



V/mA

Analog output



V/mA



Analog output, redundant



PRAS3 - Magnetic Angle Sensor
Version with analog output

Specifications

		Order options
Mechanical connection	10 mm shaft 6 mm hollow shaft	1 V H
Measurement range	0 ... 15° to 0 ... 360° (in 15° increments)	2 15 / 30 / 45 / ... / 345 / 360
Output	Voltage 0.5 ... 10 V Voltage 0.5 ... 4.5 V ratiometric Voltage 0.5 ... 4.5 V Current 4 ... 20 mA, 3 wire	3 U2 / U2B U6 U8 I1 / I1B
Signal characteristics	Signal increasing CW, clockwise Signal increasing CCW, counterclockwise	4 CW CCW
Resolution	0.03% (60 ... 360°); 0.1% (15 ... 45°)	
Repeatability	±0.03% (60 ... 360°); ±0.1% (15 ... 45°)	
Linearity	±0.3% f.s. (typical)	
Connection	5-pin connector M12 axial (compatible with 4-pin connector) 5-pin connector M12 radial (compatible with 4-pin connector) Cable, standard length 2 m Deutsch connector, not shielded	5 M12A5 M12R5 KAB2M
Housing material	Aluminum	
Mounting	Clamps, mounting plate	
Protection class	IP67/IP69	
Life cycle of bearings (shaft version)	100 x 10 ⁶ revolutions (<1500 r.p.m.)	
Revolutions per minute (mechanical)	10,000 r.p.m.	
Allowable shaft load	100 N radial / 100 N axial	
Shock	DIN EN 60068-2-27:2010, 100 g/11 ms, 100 shocks	
Vibration	DIN EN 60068-2-6:2008, 20 g 10 Hz-2 kHz, 10 cycles	
Temperature range	-40 ... +85°C	
Weight	250 g approx. (without cable)	
EMC	DIN EN 61326-1:2013	

Order code

PRAS3 – **1** – **2** – **3** – **4** – **5**

Order example: PRAS3 – V – 360 – I1 – CW – M12A5

Accessories:

Connector cable (see page 18)

Mounting plates (see page 8)



PRAS3 - Magnetic Angle Sensor
Version with analog output, redundant

Specifications

		Order options
Mechanical connection	10 mm shaft 6 mm hollow shaft	1 V H
Measurement range	0 ... 15° to 0 ... 360° (in 15° increments)	2 15 / 30 / 45 / ... / 345 / 360
Output	Voltage 0.5 ... 10 V, redundant Voltage 0.5 ... 4.5 V ratiometric, redundant Voltage 0.5 ... 4.5 V, redundant Current 4... 20 mA, 3 wire, redundant	3 U2R U6R U8R I1R
Signal characteristics	Signal 1 increasing clockwise, signal 2 increasing counterclockwise Signal 1 and signal 2 increasing clockwise* Signal 1 and signal 2 increasing counterclockwise* * not available with output I1R	4 CW/CCW CW/CW CCW/CCW
Resolution	0.03% (60 ... 360°); 0.1% (15 ... 45°)	
Repeatability	±0.03% (60 ... 360°); ±0.1% (15 ... 45°)	
Linearity	±0.3% f.s. (typical)	
Connection	8-pin connector M12 axial 8-pin connector M12 radial Cable, standard length 2 m Deutsch connector, not shielded	5 M12A8 M12R8 KAB2M
Housing material	Aluminum	
Mounting	Clamps, mounting plate	
Protection class	IP67/IP69	
Life cycle of bearings (shaft version)	100 x 10 ⁶ revolutions (<1500 r.p.m.)	
Revolutions per minute (mechanical)	10,000 r.p.m.	
Allowable shaft load	100 N radial / 100 N axial	
Shock	DIN EN 60068-2-27:2010, 100 g/11 ms, 100 shocks	
Vibration	DIN EN 60068-2-6:2008, 20 g 10 Hz-2 kHz, 10 cycles	
Temperature range	-40 ... +85°C	
Weight	250 g approx. (without cable)	
EMC	DIN EN 61326-1:2013	

Order code

PRAS3 – **1** – **2** – **3** – **4** – **5**

Order example: PRAS3 – V – 360 – U2R – CW/CCW – M12R8

Accessories:

Connector cable (see page 19)

Mounting plates (see page 8)

Dimensions

Version with shaft

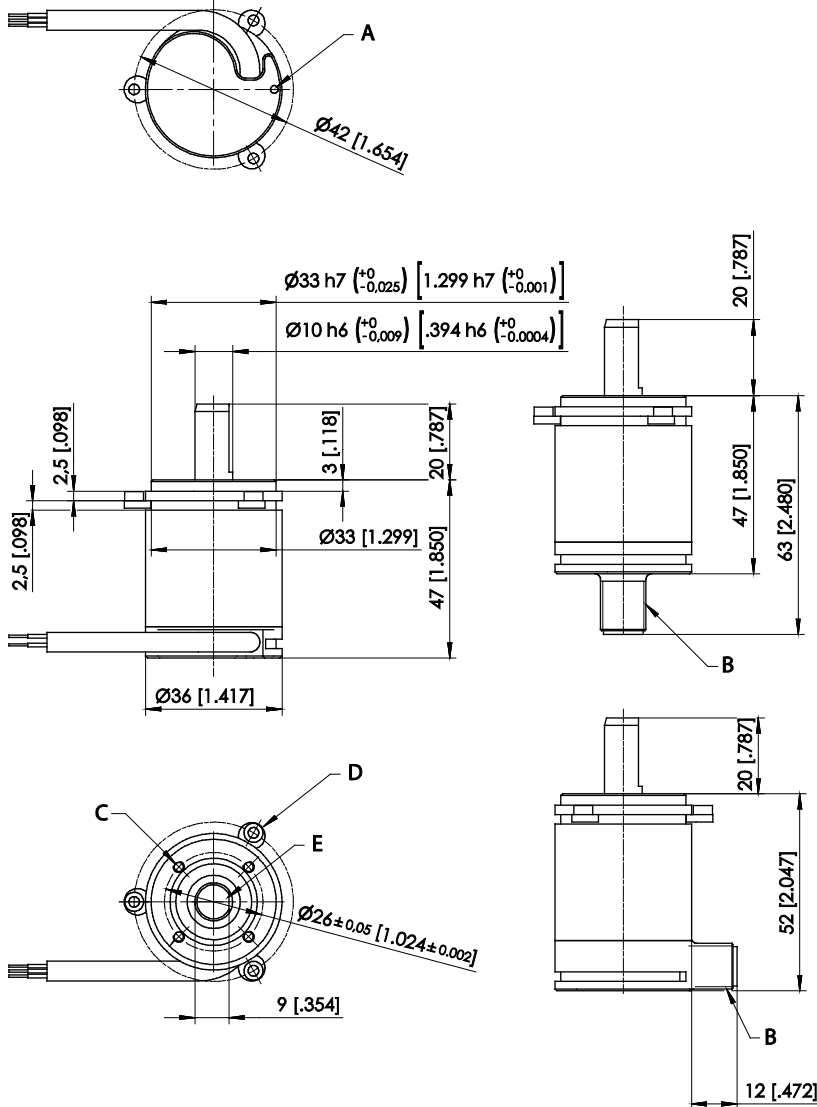

- A – Marking
- B – Connector M12
- C – 4x M3 – 5 [0.197] deep
screw hole orientation to marking not defined!
- D - Mounting clamps PRPT-BFS1
- E - Flat

Dimensions in mm [inch].
Weight approx. 250 g.
Dimensions informative only.
For guaranteed dimensions consult factory.

Version with hollow shaft

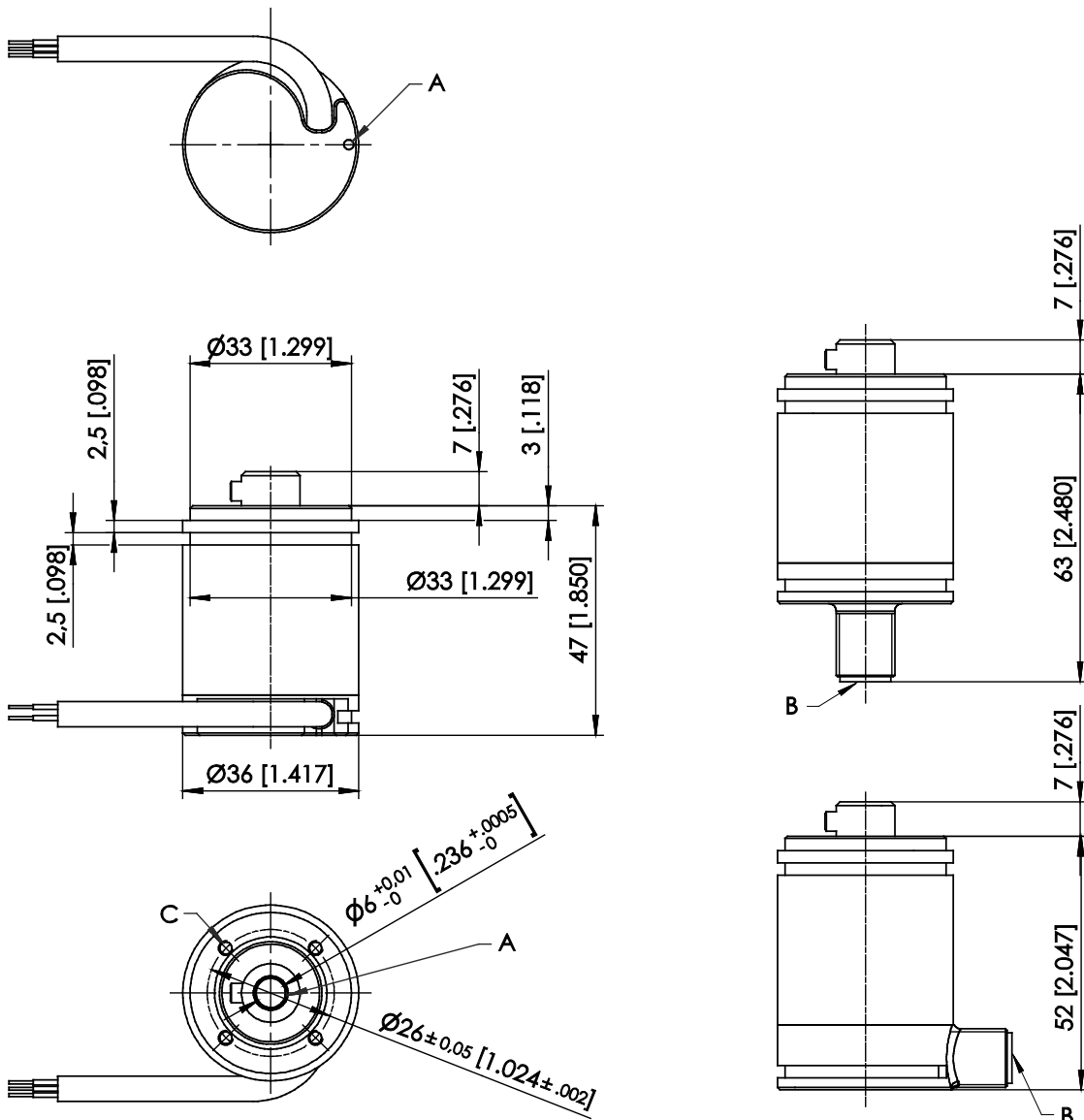

- A – Marking
- B – Connector M12
- C – 4x M3 – 5 [.197] deep
screw hole orientation to marking not defined!

Dimensions in mm [inch].
Weight approx. 250 g.
Dimensions informative only.
For guaranteed dimensions consult factory.

Mounting plates

Mounting possibilities PRxS3

Mounting possibilities of PRxS3 sensors

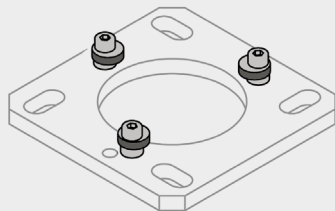

Mounting clamp BFS1

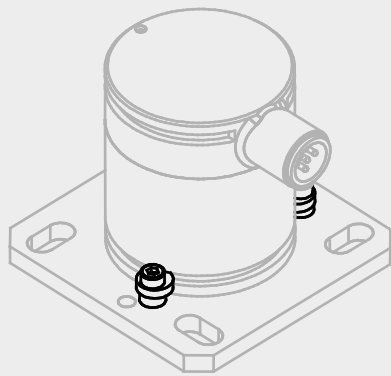

PRPT-BPL1 + PRPT-BFS1

(Mounting plates for screw mounting + mounting clamp)

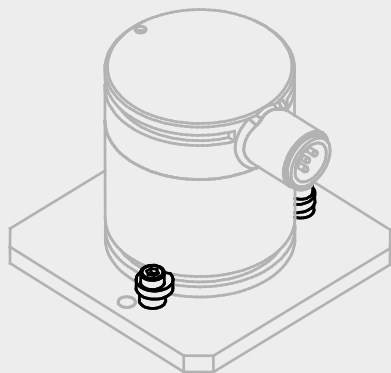

PRPT-BPL2 + PRPT-BFS1

(Mounting plates for welding assembly + mounting clamp)

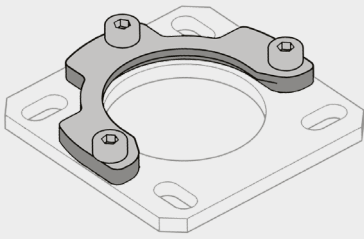

Mounting clamp BFS2

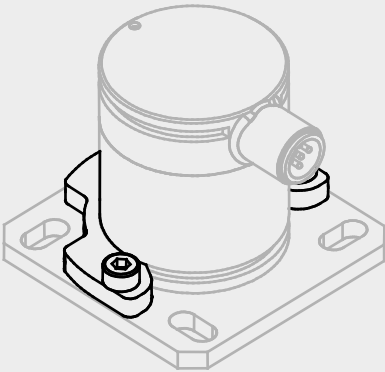

PRPT-BPL1 + PRPT-BFS2

(Mounting plates for screw mounting + mounting clamp)

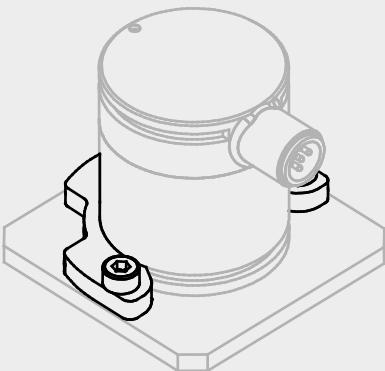

PRPT-BPL2 + PRPT-BFS2

(Mounting plates for welding assembly + mounting clamp)

PRPT-BPL1

(Screw mounting)

In combination with the mounting clamps PRPT-BFS1 (3 x M2.5) or in combination with the mounting bracket PRPT-BFS2 (3 x M4).

Dimensions in mm [inch].

Weight 30 g approx.

Dimensions informative only.

For guaranteed dimensions please consult factory.

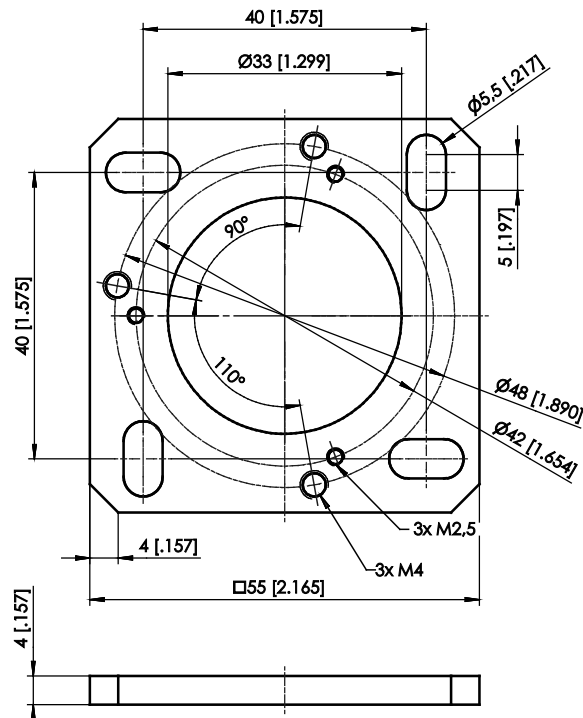

PRPT-BPL2

(Welding assembly)

In combination with the mounting clamps PRPT-BFS1 (3 x M2.5) or in combination with the mounting bracket PRPT-BFS2 (3 x M4).

Dimensions in mm [inch].

Weight 30 g approx.

Dimensions informative only.

For guaranteed dimensions please consult factory.

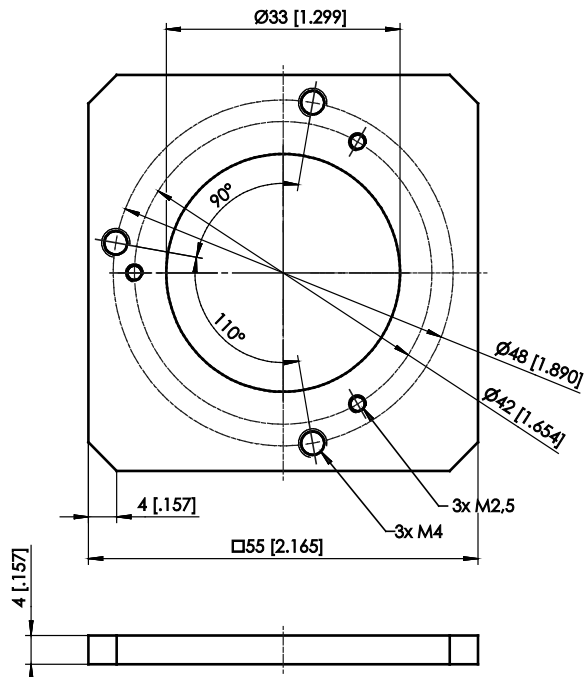

PRPT-BPL3

In combination with PRAS3/PRDS3 and frontal mounting.

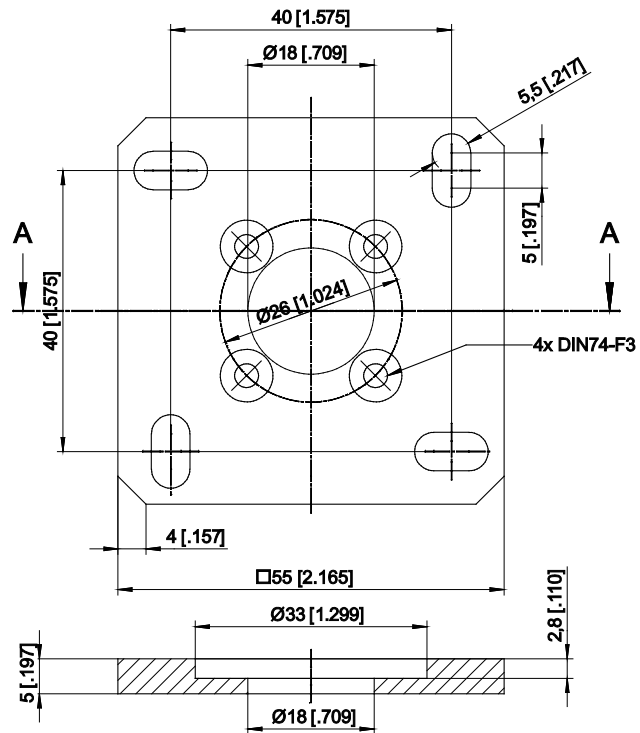

Dimensions in mm [inch]. Weight 30 g approx.

Dimensions informative only.

For guaranteed dimensions please consult factory.

Output specification

Analog output

U2 Voltage output 0.5 ... 10 V 	Excitation voltage	18 ... 36 V DC
	Excitation current	typical 10 mA max. 15 mA
	Output voltage	0.5 ... 10 V DC
	Output current	2 mA max.
	Measuring rate	1 kHz standard
	Stability (temperature)	$\pm 50 \times 10^{-6}$ / °C f.s. (typical for 90° ... 360°) $\pm 100 \times 10^{-6}$ / °C f.s. (typical for <90°)
	Protection	Reverse polarity, short circuit
	Operating temperature	-40 ... +85 °C
	EMC	DIN EN 61326-1:2013

U2B Voltage output 0.5 ... 10 V 	Excitation voltage	11.5 ... 27 V DC
	Excitation current	typical 12 mA max. 16 mA
	Output voltage	0,5 ... 10 V DC
	Output current	2 mA max.
	Measuring rate	1 kHz standard
	Stability (temperature)	$\pm 50 \times 10^{-6}$ / °C f.s. (typical for 90° ... 360°) $\pm 100 \times 10^{-6}$ / °C f.s. (typical for <90°)
	Protection	Reverse polarity, short circuit
	Operating temperature	-40 ... +85 °C
	EMC	DIN EN 61326-1:2013

U6 Voltage output 10 ... 90 % ratiometric 	Excitation voltage	5 V DC ±10 %
	Excitation current	typical 8 mA max. 12 mA
	Output voltage	10 ... 90 % of the excitation voltage
	Output current	2 mA max.
	Measuring rate	1 kHz standard
	Stability (temperature)	±50 x 10 ⁻⁶ / °C f.s. (typical for 90° ... 360°) ±100 x 10 ⁻⁶ / °C f.s. (typical for <90°)
	Protection	Reverse polarity, short circuit
	Operating temperature	-40 ... +85 °C
	EMC	DIN EN 61326-1:2013

U8 Voltage output 0.5 ... 4.5 V 	Excitation voltage	11 ... 36 V DC
	Excitation current	typical 10 mA max. 20 mA
	Output voltage	0.5 ... 4.5 V DC
	Output current	2 mA max.
	Measuring rate	1 kHz standard
	Stability (temperature)	±50 x 10 ⁻⁶ / °C f.s. (typical for 90° ... 360°) ±100 x 10 ⁻⁶ / °C f.s. (typical for <90°)
	Protection	Reverse polarity, short circuit
	Operating temperature	-40 ... +85 °C
	EMC	DIN EN 61326-1:2013

I1 Current output 4 ... 20 mA, 3 wires 	Excitation voltage	18 ... 36 V DC
	Excitation current	typical 30 mA max. 35 mA
	Load R_L	500 Ω max.
	Output current	4 ... 20 mA
	Measuring rate	1 kHz standard
	Stability (temperature)	$\pm 50 \times 10^{-6}$ / °C f.s. (typical for 90° ... 360°) $\pm 100 \times 10^{-6}$ / °C f.s. (typical for <90°)
	Protection	Reverse polarity, short circuit
	Operating temperature	-40 ... +85 °C
	EMC	DIN EN 61326-1:2013

I1B Current output 4 ... 20 mA, 3 wires 	Excitation voltage	10 ... 27 V DC
	Excitation current	typical 32 mA max. 36 mA
	Load R_L	250 Ω max.
	Output current	4 ... 20 mA
	Measuring rate	1 kHz standard
	Stability (temperature)	$\pm 50 \times 10^{-6}$ / °C f.s. (typical for 90° ... 360°) $\pm 100 \times 10^{-6}$ / °C f.s. (typical for <90°)
	Protection	Reverse polarity, short circuit
	Operating temperature	-40 ... +85 °C
	EMC	DIN EN 61326-1:2013

Analog output, 1 channel (connector and cable output)

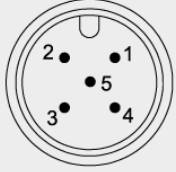
Signal wiring	Output signals	Connector pin no.	Cable color
Connector M12, 5 pin  View to the sensor connector	Excitation +	1	brown
	Signal	2	white
	GND	3	blue
	Do not connect!	4	black
	Do not connect!	5	grey

3-wire current 4...20 mA interface: GND has to be connected!

Analog output, redundant

U2R Voltage output 0.5 ... 10 V 	Excitation voltage	18 ... 36 V DC
	Excitation current	typical 10 mA max. 15 mA per channel
	Output voltage	0.5 ... 10 V DC
	Output current	2 mA max.
	Measuring rate	1 kHz Standard
	Stability (temperature)	$\pm 50 \times 10^{-6}$ / °C f.s. (typical for 90° ... 360°) $\pm 100 \times 10^{-6}$ / °C f.s. (typical for <90°)
	Protection	Reverse polarity, short circuit
	Operating temperature	-40 ... +85 °C
	EMC	DIN EN 61326-1:2013

U6R Voltage output 10 ... 90 % ratiometric 	Excitation voltage	5 V DC ± 10 %
	Excitation current	typical 8 mA max. 12 mA per channel
	Output voltage	10 ... 90 % of the excitation voltage
	Output current	2 mA max.
	Measuring rate	1 kHz standard
	Stability (temperature)	$\pm 50 \times 10^{-6}$ / °C f.s. (typical for 90° ... 360°) $\pm 100 \times 10^{-6}$ / °C f.s. (typical for <90°)
	Protection	Reverse polarity, short circuit
	Operating temperature	-40 ... +85 °C
	EMC	EN 61326-1:2013

U8R Voltage output 0.5 ... 4.5 V 	Excitation voltage	11 ... 36 V DC
	Excitation current	typical 10 mA max. 20 mA per channel
	Output voltage	0.5 ... 4,5 V DC
	Output current	2 mA max.
	Measuring rate	1 kHz standard
	Stability (temperature)	±50 x 10 ⁻⁶ / °C f.s. (typical for 90° ... 360°) ±100 x 10 ⁻⁶ / °C f.s. (typical for <90°)
	Protection	Reverse polarity, short circuit
	Operating temperature	-40 ... +85 °C
	EMC	DIN EN 61326-1:2013

I1R Current output 4 ... 20 mA, 3 wires 	Excitation voltage	18 ... 36 V DC
	Excitation current	typical 30 mA max. 35 mA per channel
	Load R _L	500 Ω max.
	Output current	4 ... 20 mA
	Measuring rate	1 kHz standard
	Stability (temperature)	±50 x 10 ⁻⁶ / °C f.s. (typical for 90° ... 360°) ±100 x 10 ⁻⁶ / °C f.s. (typical for <90°)
	Protection	Reverse polarity, short circuit
	Operating temperature	-40 ... +85 °C
	EMC	DIN EN 61326-1:2013

Analog output, 2 channels, redundant (connector and cable output)

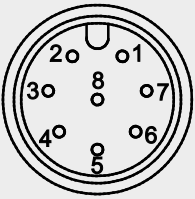
Signal wiring	Channel	Output signals	Connector pin no.	Cable color
Connector M12, 8 pin  View to the sensor connector	1	Excitation +	1	white
		Signal	2	brown
		GND	3	green
		Do not connect!	4	yellow
	2	Excitation +	5	grey
		Signal	6	pink
		GND	7	blue
		Do not connect!	8	red

Characteristics for magnetic angle sensors

Output signal CW

(clockwise increasing)

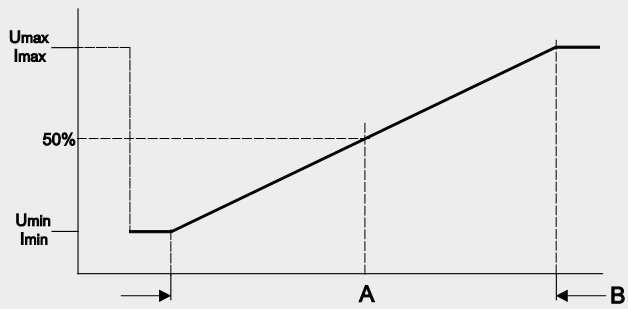

Output signal CCW

(counterclockwise increasing)

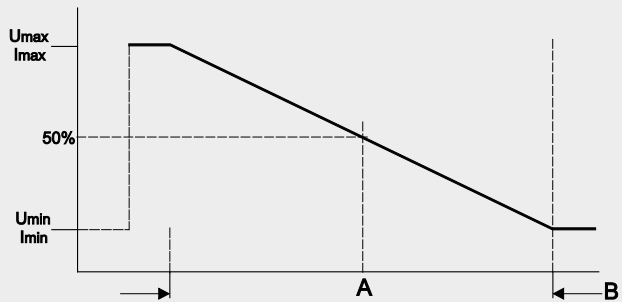

Example angular range 90°

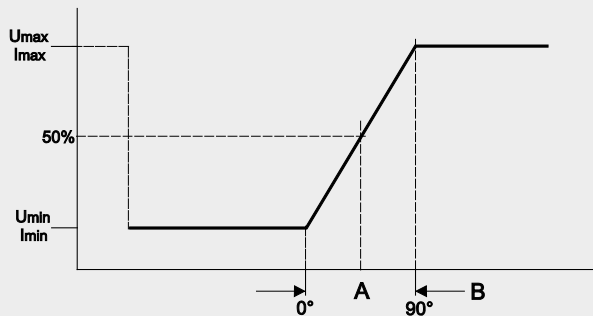

Example angular range 360°

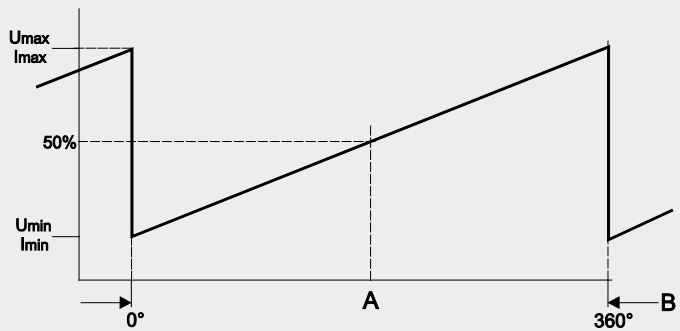

A – Marking

B – Measurement range [$^\circ$]

Accessories
Connector cable M12, 4 pin
(angular coupling)

shielded connector
Suitable for 5-pin
sensor connectors

The 4-core screened cable is supplied with a mating 4-pin 90° M12 connector at one end and 4 wires at the other end. Available lengths are 2 m, 5 m and 10 m.
Wire: cross sectional area 0.34 mm²
Cable diameter: 5.6 ±0.2 mm

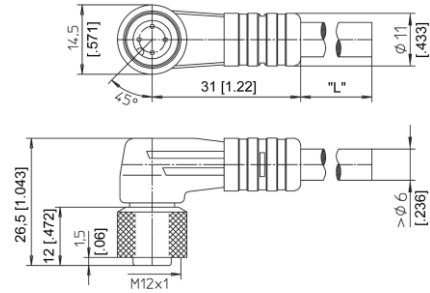

Order code

KAB - xM - M12/4F/W - LITZE

IP69: **KAB - xM - M12/4F/W/69K - LITZE**

xM = length in m

Connector cable M12, 4 pin
(straight coupling)

shielded connector
Suitable for 5-pin
sensor connectors

The 4-core screened cable is supplied with a mating 4-pin M12 connector at one end and 4 wires at the other end. Available lengths are 2 m, 5 m and 10 m.
Wire: cross sectional area 0.34 mm²
Cable diameter: 5.6 ±0.2 mm

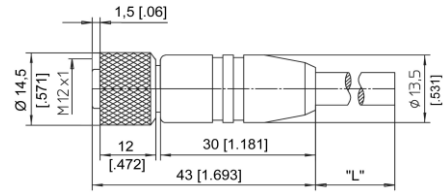

Order code

KAB - xM - M12/4F/G - LITZE

IP69: **KAB - xM - M12/4F/G/69K - LITZE**

xM = length in m

Signal wiring M12, 4 pin	Plug connection / cable color			
	1	2	3	4
	brown	white	blue	black

Applicable for cable carriers

Maximum movement speed	3 m/s
Maximum acceleration	5 m/s ²
Minimum bending radius	10 x cable diameter

Connector cable M12, 8 pin (angular coupling)

shielded connector

The 8-lead shielded cable is supplied with a mating 8-pin 90° M12 connector at one end and 8 wires at the other end. Available lengths are 2 m, 5 m and 10 m.
Wire: cross sectional area 0.25 mm²
Cable diameter: 6.3 ±0.2 mm

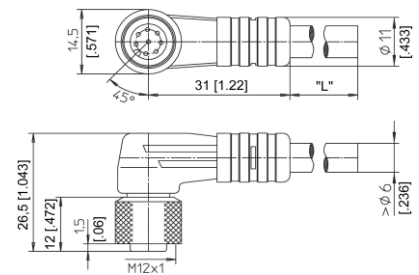

Order code

KAB - xM - M12/8F/W - LITZE

IP69: **KAB - xM - M12/8F/W/69K - LITZE**

xM = length in m

Connector cable M12, 8 pin (straight coupling)

shielded connector

The 8-lead shielded cable is supplied with a mating 8-pin M12 connector at one end and 8 wires at the other end. Available lengths are 2 m, 5 m and 10 m.
Wire: cross sectional area 0.25 mm²
Cable diameter: 6.3 ±0.2 mm

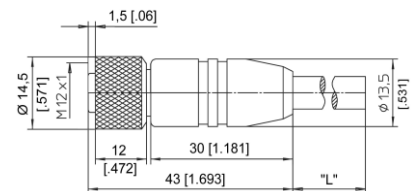

Order code

KAB - xM - M12/8F/G - LITZE

IP69: **KAB - xM - M12/8F/G/69K - LITZE**

xM = length in m

Signal wiring M12, 8 pin	Plug connection / cable color							
	1	2	3	4	5	6	7	8
	white	brown	green	yellow	grey	pink	blue	red

Applicable for cable carriers

Maximum movement speed	3 m/s
Maximum acceleration	5 m/s ²
Minimum bending radius	10 x cable diameter