

 PRAS2

Angle sensor for standard industrial applications



- Measurement range 0°... 360°
- Protection class IP67/IP69
- Diameter 36 mm, overall height 20 mm / 25 mm
- Contactless with external position magnet, wear-free

### Product versions



Analog output



Analog output, redundant



PRAS2 - Magnetic Angle Sensor  
Version with analog output

Specifications

		Order options
Measurement range	0 ... 15° to 0 ... 360° (in 15° increments)	<b>1</b> 15 / 30 / 45 / ... / 345 / 360
Output	Voltage 0.5 ... 10 V Voltage 0.5 ... 4.5 V ratiometric Voltage 0.5 ... 4.5 V Current 4 ... 20 mA, 3 wire	<b>2</b> U2 / U2B U6 U8 I1 / I1B
Signal characteristics	Signal increasing CW, clockwise Signal increasing CCW, counterclockwise	<b>3</b> CW CCW
Resolution	0.03% (60 ... 360°); 0.1% (15 ... 45°)	
Repeatability	±0.03% (60 ... 360°); ±0.1% (15 ... 45°)	
Linearity	±0.3% f.s. (typical)	
Rated distance sensor / magnet	Depending on the position magnet	
Housing material	Aluminum	
Mounting	Clamps, mounting plate	
Protection class	IP67/IP69	
Connection	5-pin connector M12 axial (compatible with 4-pin connector) 5-pin connector M12 radial (compatible with 4-pin connector) Cable, standard length 2 m Deutsch connector, not shielded	<b>4</b> M12A5 M12R5 KAB2M
Shock	DIN EN 60068-2-27:2010, 100 g/11 ms, 100 shocks	
Vibration	DIN EN 60068-2-6:2008, 20 g 10 Hz-2 kHz, 10 cycles	
Temperature range	-40 ... +85°C	
Weight	50 g approx. (without cable)	
EMC	DIN EN 61326-1:2013	

Order code

PRAS2 – **1** – **2** – **3** – **4**

Order example: PRAS2 – 360 – I1 – CW – M12A5

Accessories:

Connector cable (see page 21)

Position magnets (see from page 7)

Mounting (see page 12)

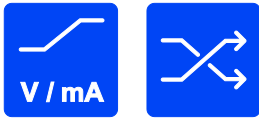

PRAS2 - Magnetic Angle Sensor  
Version with analog output, redundant

Specifications

		Order options	
Measurement range	0 ... 15° to 0 ... 360° (in 15° increments)	<b>1</b>	15 / 30 / 45 / ... / 345 / 360
Output	Voltage 0.5 ... 10 V, redundant Voltage 0.5 ... 4.5 V ratiometric, redundant Voltage 0.5 ... 4.5 V, redundant Current 4... 20 mA, 3 wire, redundant	<b>2</b>	U2R U6R U8R I1R
Signal characteristics	Signal 1 increasing clockwise, signal 2 increasing counterclockwise Signal 1 and signal 2 increasing clockwise* Signal 1 and signal 2 increasing counterclockwise*  * not available with output I1R	<b>3</b>	CW/CCW  CW/CW CCW/CCW
Resolution	0.03% (60 ... 360°); 0.1% (15 ... 45°)		
Repeatability	±0.03% (60 ... 360°); ±0.1% (15 ... 45°)		
Linearity	±0.3% f.s. (typical)		
Rated distance sensor / magnet	Depending on the position magnet		
Housing material	Aluminum		
Mounting	Clamps, mounting plate		
Protection class	IP67/IP69		
Connection	8-pin connector M12 axial 8-pin connector M12 radial Cable, standard length 2 m Deutsch connector, not shielded	<b>4</b>	M12A8 M12R8 KAB2M
Shock	DIN EN 60068-2-27:2010, 100 g/11 ms, 100 shocks		
Vibration	DIN EN 60068-2-6:2008, 20 g 10 Hz-2 kHz, 10 cycles		
Temperature range	-40 ... +85°C		
Weight	50 g approx. (without cable)		
EMC	DIN EN 61326-1:2013		

Order code

PRAS2	-	<b>1</b>	-	<b>2</b>	-	<b>3</b>	-	<b>4</b>
-------	---	----------	---	----------	---	----------	---	----------

Order example: PRAS2 – 360 – U2R – CW/CCW – M12R8

Accessories:

Connector cable (see page 22)

Position magnets (see from page 7)

Mounting (see page 12)

## Dimensions

### Connector M12, axial

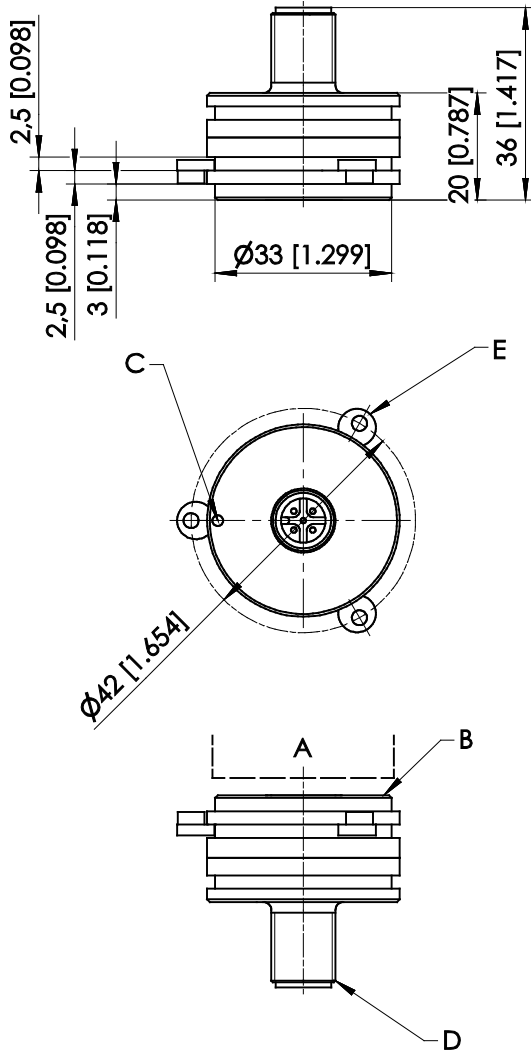

- A – Position magnet
- B – Measuring area
- C – Marking
- D – Connector M12
- E – Mounting clamps PRPT-BFS1

Dimensions in mm [inch]. Weight approx. 50 g.  
Dimensions informative only.  
For guaranteed dimensions consult factory.

Connector M12, radial

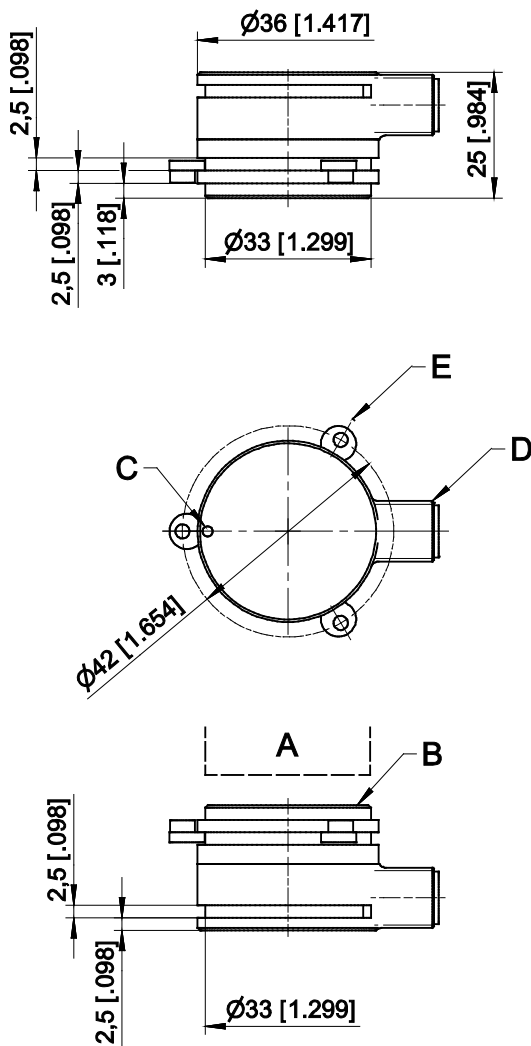

- A – Position magnet
- B – Measuring area
- C – Marking
- D – Connector M12

Dimensions in mm [inch]. Weight approx. 50 g.  
Dimensions informative only.  
For guaranteed dimensions consult factory.

Cable output

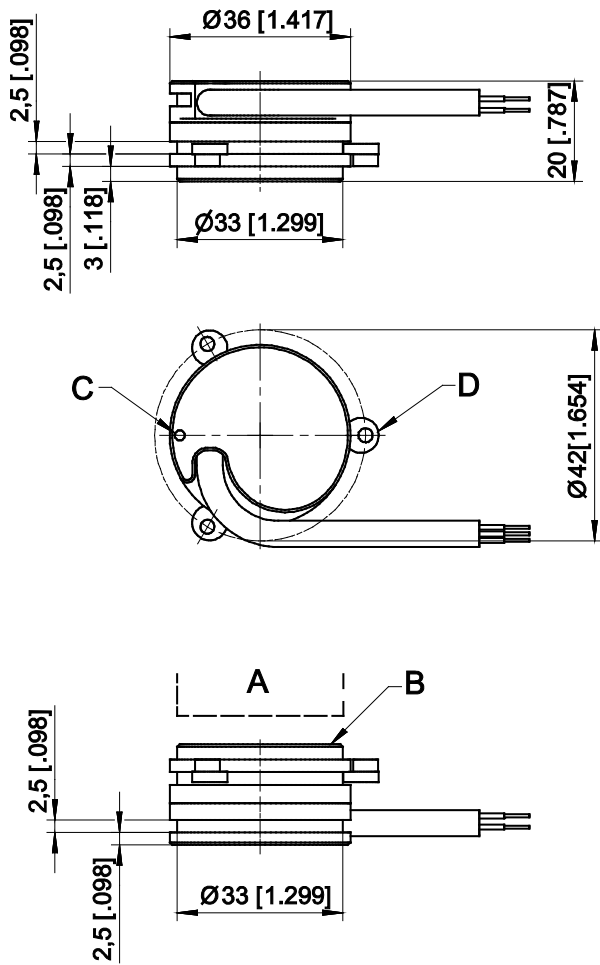

- A – Position magnet
- B – Measuring area
- C – Marking
- D – Mounting clamps PRPT-BFS1

Dimensions in mm [inch]. Weight without cable approx. 40 g.  
Dimensions informative only.  
For guaranteed dimensions consult factory.

## Position magnets

### PRMAG20

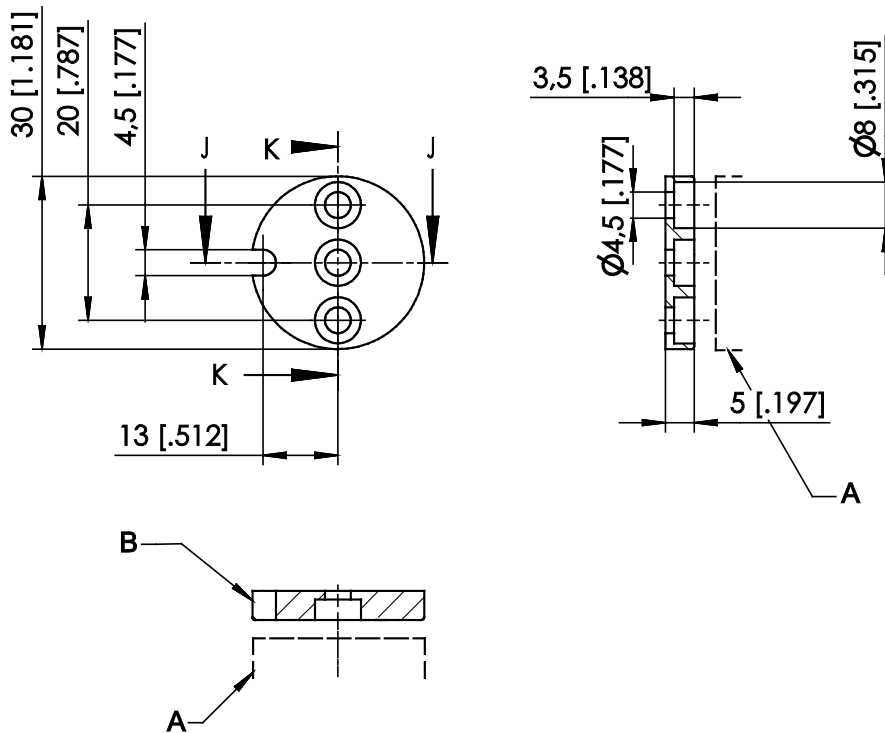

A – Sensor  
B – Marking

Order code	Weight	Material	Moment of inertia
PRMAG20	approx. 12 g	zinc coated steel, plastic	1.3 kgmm <sup>2</sup>

A misalignment of the position magnet has an effect on the linearity.

Dimensions in mm [inch].

Dimensions informative only.

For guaranteed dimensions please consult factory.

PRMAG21

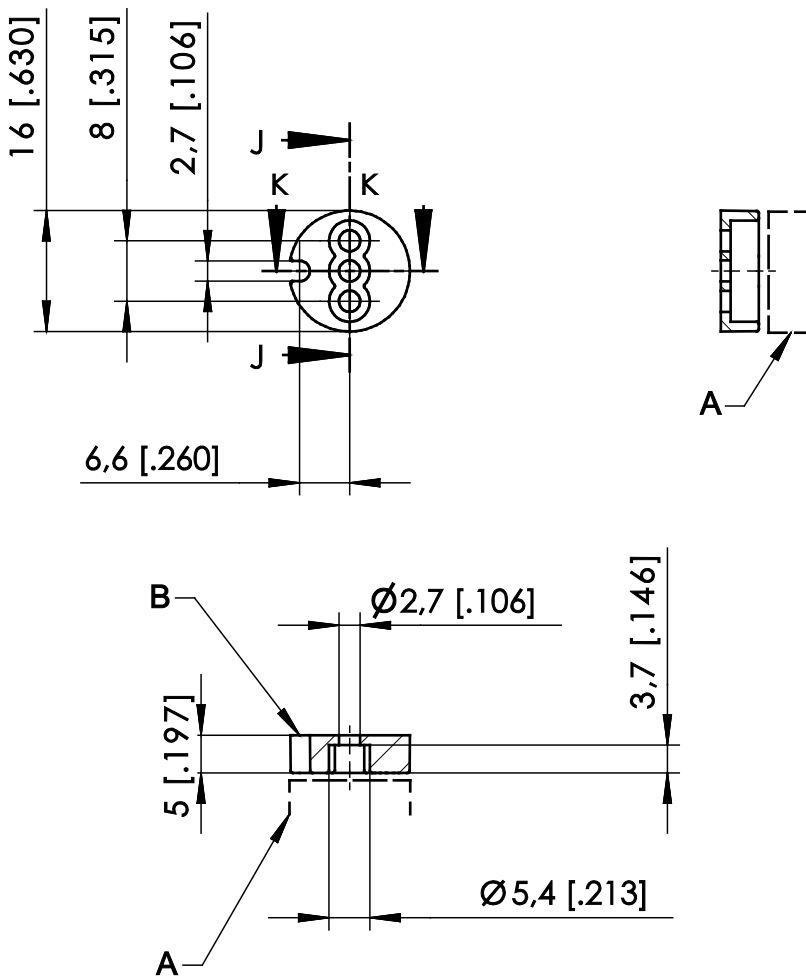

A – Sensor  
B – Marking

Order code	Weight	Material	Moment of inertia
PRMAG21	approx. 3 g	zinc coated steel; plastic	0.1 kgmm <sup>2</sup>

A misalignment of the position magnet has an effect on the linearity.

Dimensions in mm [inch]

Dimensions informative only.

For guaranteed dimensions please consult factory.



PRMAG22

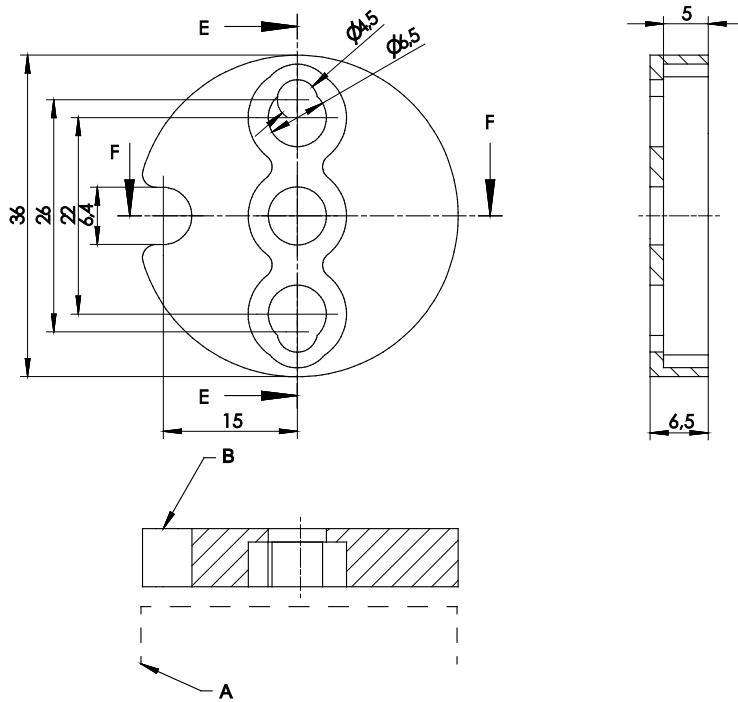

A – Sensor  
B – Marking

Order code	Weight	Material	Moment of inertia
PRMAG22	approx. 19 g	zinc coated steel, plastic	3 kgmm <sup>2</sup>

A misalignment of the position magnet has an effect on the linearity.

Dimensions in mm [inch].

Dimensions informative only

For guaranteed dimensions please consult factory.

PRMAG2-Z / PRMAG2-Z-VA

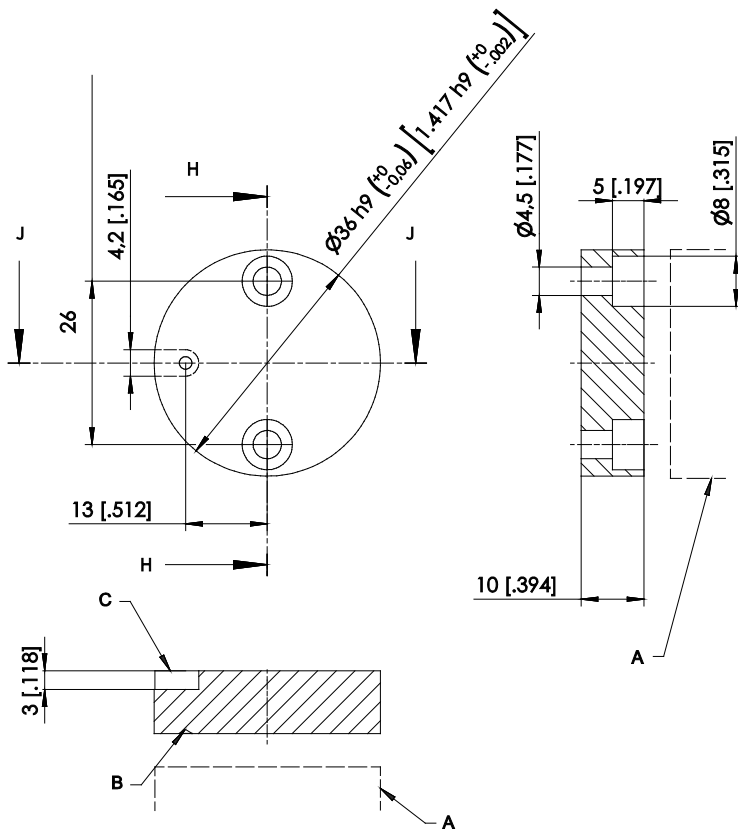

- A – Sensor
- B – Marking
- C – Notch

Order code	Weight	Material	Moment of inertia
PRMAG2-Z	approx. 30 g	AlMgSi1	4.9 kgmm <sup>2</sup>
PRMAG2-Z-VA	approx. 67 g	stainless steel 1.4404	10.9 kgmm <sup>2</sup>

A misalignment of the position magnet has an effect on the linearity.

Dimensions in mm [inch].

Dimensions informative only.

For guaranteed dimensions please consult factory.

Measuring error by misalignment of the position magnet

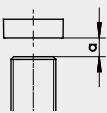
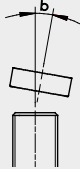
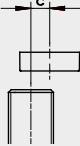
					Air gap (a) Parallelism (b) Axial misalignment (c)					
Sensor	Position magnet	Air gap [mm]	Parallelism [°]	Error by axial misalignment [°]						
				0.2 mm	0.5 mm	1 mm	2 mm	3 mm	4 mm	
PRAS2	PRMAG20	0 ... 6	0 ... 5	0.15	0.4	0.8	2.2	5	–	
	PRDS2	PRMAG21	0 ... 3.5	0 ... 5	0.2	0.4	1	3.8	10	–
	PRMAG22	0 ... 9	0 ... 5	0.1	0.4	1	2.2	4.5	8.0	
	PRMAG2-Z-VA	0 ... 9	0 ... 5	0.1	0.2	0.6	1.5	4.5	8.5	

## Mounting plates

### Mounting possibilities PRxS2

#### Mounting possibilities of PRxS2 sensors

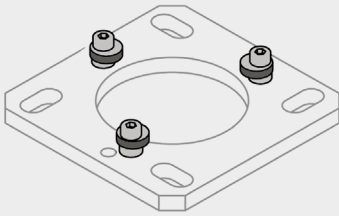

Mounting clamp BFS1

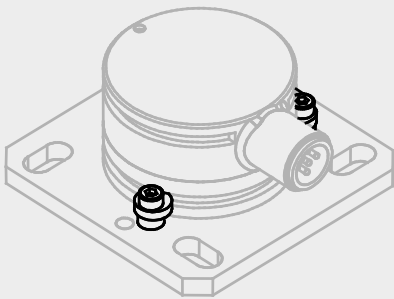

**PRPT-BPL1 + PRPT-BFS1**

(Mounting plates for screw mounting + mounting clamp)

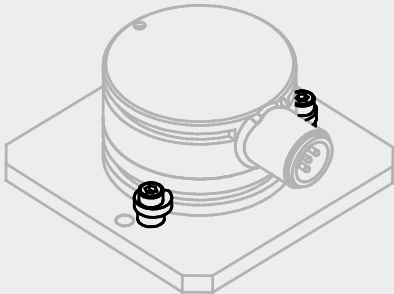

**PRPT-BPL2 + PRPT-BFS1**

(Mounting plates for welding assembly + mounting clamp)

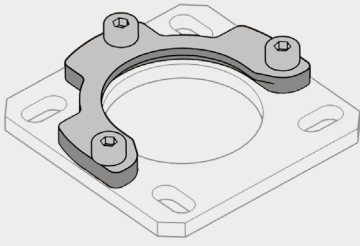

**Mounting clamp BFS2**

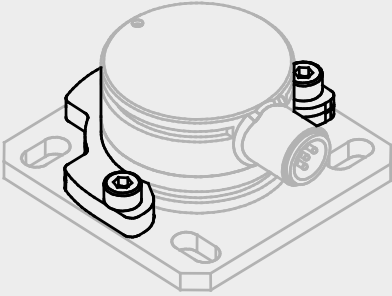

**PRPT-BPL1 + PRPT-BFS2**

(Mounting plates for screw mounting + mounting clamp)

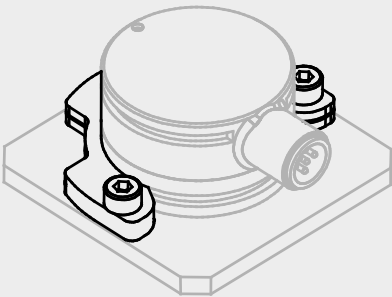

**PRPT-BPL2 + PRPT-BFS2**

(Mounting plates for welding assembly + mounting clamp)

**PRPT-BPL1**

(Screw mounting)

In combination with the mounting clamps PRPT-BFS1 (3 x M2.5) or in combination with the mounting bracket PRPT-BFS2 (3 x M4).

Dimensions in mm [inch].

Weight 30 g approx.

Dimensions informative only.

For guaranteed dimensions please consult factory.

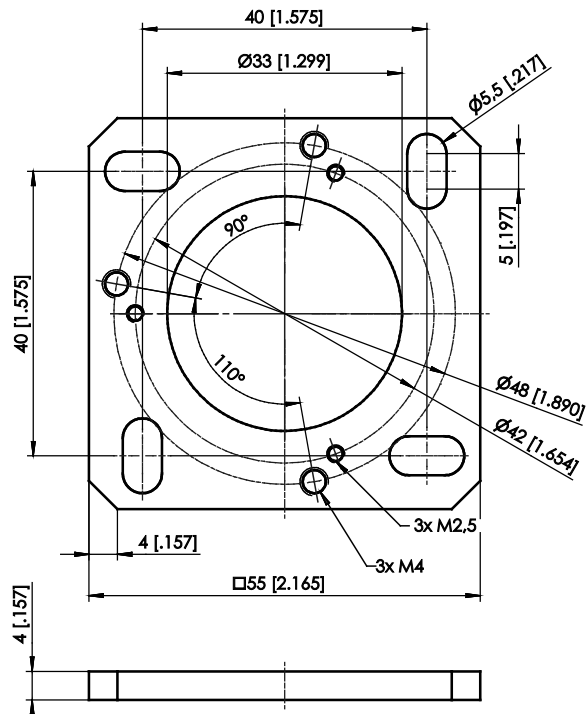

**PRPT-BPL2**

(Welding assembly)

In combination with the mounting clamps PRPT-BFS1 (3 x M2.5) or in combination with the mounting bracket PRPT-BFS2 (3 x M4).

Dimensions in mm [inch].

Weight 30 g approx.

Dimensions informative only.

For guaranteed dimensions please consult factory.

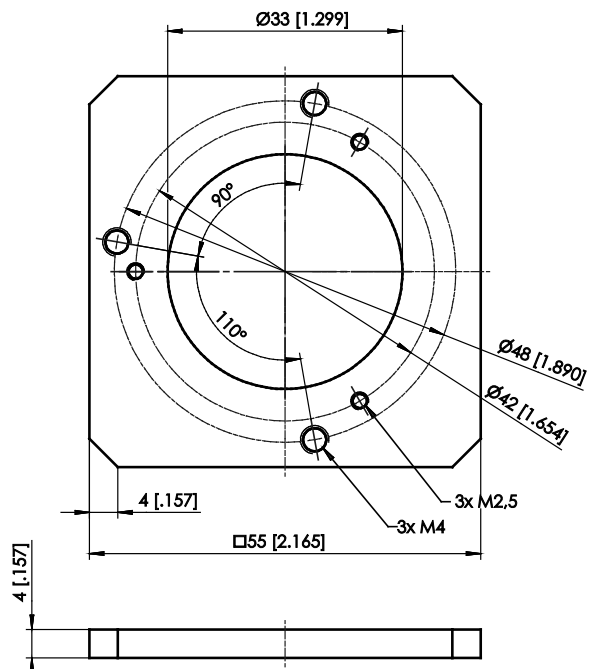



## Output specification

### Analog output

<b>U2</b> Voltage output 0.5 ... 10 V 	Excitation voltage	18 ... 36 V DC
	Excitation current	typical 10 mA max. 15 mA
	Output voltage	0.5 ... 10 V DC
	Output current	2 mA max.
	Measuring rate	1 kHz standard
	Stability (temperature)	$\pm 50 \times 10^{-6}$ / °C f.s. (typical for 90° ... 360°) $\pm 100 \times 10^{-6}$ / °C f.s. (typical for <90°)
	Protection	Reverse polarity, short circuit
	Operating temperature	-40 ... +85 °C
	EMC	DIN EN 61326-1:2013

<b>U2B</b> Voltage output 0.5 ... 10 V 	Excitation voltage	11.5 ... 27 V DC
	Excitation current	typical 12 mA max. 16 mA
	Output voltage	0,5 ... 10 V DC
	Output current	2 mA max.
	Measuring rate	1 kHz standard
	Stability (temperature)	$\pm 50 \times 10^{-6}$ / °C f.s. (typical for 90° ... 360°) $\pm 100 \times 10^{-6}$ / °C f.s. (typical for <90°)
	Protection	Reverse polarity, short circuit
	Operating temperature	-40 ... +85 °C
	EMC	DIN EN 61326-1:2013

<b>U6</b> Voltage output 10 ... 90 % ratiometric 	Excitation voltage	5 V DC ±10 %
	Excitation current	typical 8 mA max. 12 mA
	Output voltage	10 ... 90 % of the excitation voltage
	Output current	2 mA max.
	Measuring rate	1 kHz standard
	Stability (temperature)	±50 x 10 <sup>-6</sup> / °C f.s. (typical for 90° ... 360°) ±100 x 10 <sup>-6</sup> / °C f.s. (typical for <90°)
	Protection	Reverse polarity, short circuit
	Operating temperature	-40 ... +85 °C
	EMC	DIN EN 61326-1:2013

<b>U8</b> Voltage output 0.5 ... 4.5 V 	Excitation voltage	11 ... 36 V DC
	Excitation current	typical 10 mA max. 20 mA
	Output voltage	0.5 ... 4.5 V DC
	Output current	2 mA max.
	Measuring rate	1 kHz standard
	Stability (temperature)	±50 x 10 <sup>-6</sup> / °C f.s. (typical for 90° ... 360°) ±100 x 10 <sup>-6</sup> / °C f.s. (typical for <90°)
	Protection	Reverse polarity, short circuit
	Operating temperature	-40 ... +85 °C
	EMC	DIN EN 61326-1:2013



<b>I1</b> Current output 4 ... 20 mA, 3 wires 	Excitation voltage	18 ... 36 V DC
	Excitation current	typical 30 mA max. 35 mA
	Load R <sub>L</sub>	500 Ω max.
	Output current	4 ... 20 mA
	Measuring rate	1 kHz standard
	Stability (temperature)	±50 x 10 <sup>-6</sup> / °C f.s. (typical for 90° ... 360°) ±100 x 10 <sup>-6</sup> / °C f.s. (typical for <90°)
	Protection	Reverse polarity, short circuit
	Operating temperature	-40 ... +85 °C
	EMC	DIN EN 61326-1:2013

<b>I1B</b> Current output 4 ... 20 mA, 3 wires 	Excitation voltage	10 ... 27 V DC
	Excitation current	typical 32 mA max. 36 mA
	Load R <sub>L</sub>	250 Ω max.
	Output current	4 ... 20 mA
	Measuring rate	1 kHz standard
	Stability (temperature)	±50 x 10 <sup>-6</sup> / °C f.s. (typical for 90° ... 360°) ±100 x 10 <sup>-6</sup> / °C f.s. (typical for <90°)
	Protection	Reverse polarity, short circuit
	Operating temperature	-40 ... +85 °C
	EMC	DIN EN 61326-1:2013

**Analog output, 1 channel (connector and cable output)**

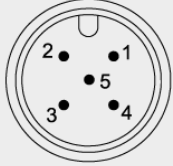
Signal wiring	Output signals	Connector pin no.	Cable color
<b>Connector M12, 5 pin</b>  View to the sensor connector	Excitation +	1	brown
	Signal	2	white
	GND	3	blue
	Do not connect!	4	black
	Do not connect!	5	grey

3-wire current 4...20 mA interface: GND has to be connected!

**Analog output, redundant**

<b>U2R</b> Voltage output 0.5 ... 10 V 	Excitation voltage	18 ... 36 V DC
	Excitation current	typical 10 mA max. 15 mA per channel
	Output voltage	0.5 ... 10 V DC
	Output current	2 mA max.
	Measuring rate	1 kHz Standard
	Stability (temperature)	±50 x 10 <sup>-6</sup> / °C f.s. (typical for 90° ... 360°) ±100 x 10 <sup>-6</sup> / °C f.s. (typical for <90°)
	Protection	Reverse polarity, short circuit
	Operating temperature	-40 ... +85 °C
	EMC	DIN EN 61326-1:2013

<b>U6R</b> Voltage output 10 ... 90 % ratiometric 	Excitation voltage	5 V DC ±10 %
	Excitation current	typical 8 mA max. 12 mA per channel
	Output voltage	10 ... 90 % of the excitation voltage
	Output current	2 mA max.
	Measuring rate	1 kHz standard
	Stability (temperature)	±50 x 10 <sup>-6</sup> / °C f.s. (typical for 90° ... 360°) ±100 x 10 <sup>-6</sup> / °C f.s. (typical for <90°)
	Protection	Reverse polarity, short circuit
	Operating temperature	-40 ... +85 °C
	EMC	EN 61326-1:2013

<b>U8R</b> Voltage output 0.5 ... 4.5 V 	Excitation voltage	11 ... 36 V DC
	Excitation current	typical 10 mA max. 20 mA per channel
	Output voltage	0.5 ... 4,5 V DC
	Output current	2 mA max.
	Measuring rate	1 kHz standard
	Stability (temperature)	$\pm 50 \times 10^{-6}$ / °C f.s. (typical for 90° ... 360°) $\pm 100 \times 10^{-6}$ / °C f.s. (typical for <90°)
	Protection	Reverse polarity, short circuit
	Operating temperature	-40 ... +85 °C
	EMC	DIN EN 61326-1:2013

<b>I1R</b> Current output 4 ... 20 mA, 3 wires 	Excitation voltage	18 ... 36 V DC
	Excitation current	typical 30 mA max. 35 mA per channel
	Load R <sub>L</sub>	500 Ω max.
	Output current	4 ... 20 mA
	Measuring rate	1 kHz standard
	Stability (temperature)	$\pm 50 \times 10^{-6}$ / °C f.s. (typical for 90° ... 360°) $\pm 100 \times 10^{-6}$ / °C f.s. (typical for <90°)
	Protection	Reverse polarity, short circuit
	Operating temperature	-40 ... +85 °C
	EMC	DIN EN 61326-1:2013

**Analog output 2 channels, redundant (connector and cable output)**

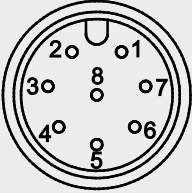
Signal wiring	Channel	Output signals	Connector pin no.	Cable color
<b>Connector M12, 8 pin</b>  View to the sensor connector	1	Excitation +	1	white
		Signal	2	brown
		GND	3	green
		Do not connect!	4	yellow
	2	Excitation +	5	grey
		Signal	6	pink
		GND	7	blue
		Do not connect!	8	red

## Characteristics for magnetic angle sensors

**Output signal CW**  
(clockwise increasing)

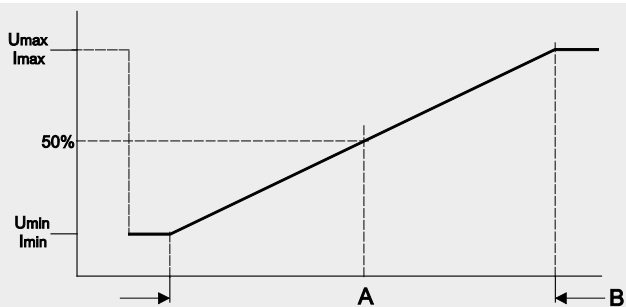

**Output signal CCW**  
(counterclockwise increasing)

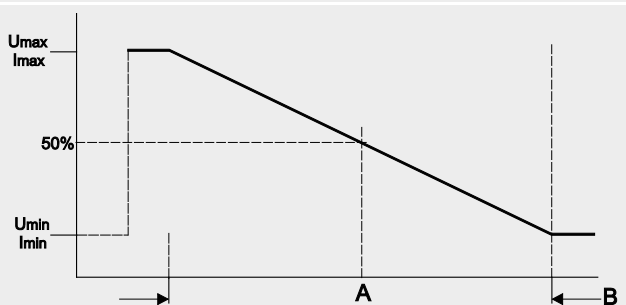

Example angular range 90°

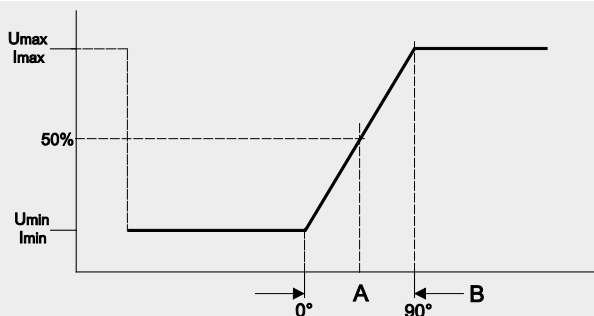

Example angular range 360°

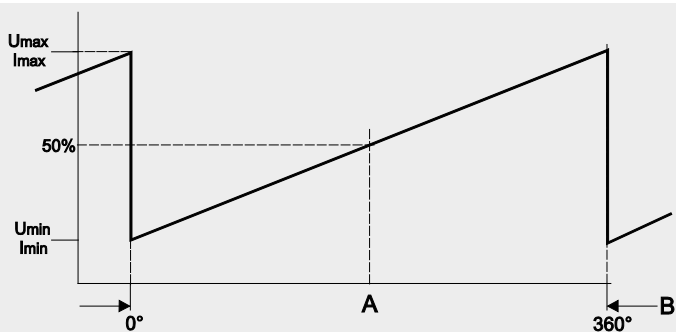

A – Marking

B – Measurement range [°]

**Accessories**  
**Connector cable M12, 4 pin**  
**(angular coupling)**

shielded connector  
Suitable for 5-pin  
sensor connectors

The 4-core screened cable is supplied with a mating 4-pin 90° M12 connector at one end and 4 wires at the other end. Available lengths are 2 m, 5 m and 10 m. Wire: cross sectional area 0.34 mm<sup>2</sup>  
Cable diameter: 5.6 ±0.2 mm

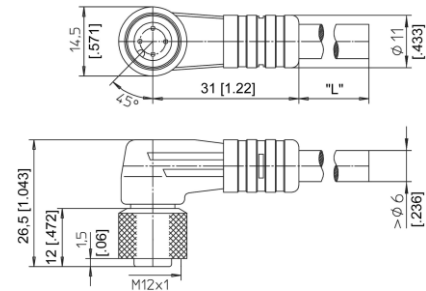

**Order code**

**KAB - xM - M12/4F/W - LITZE**

IP69: **KAB - xM - M12/4F/W/69K - LITZE**

xM = length in m

**Connector cable M12, 4 pin**  
**(straight coupling)**

shielded connector  
Suitable for 5-pin  
sensor connectors

The 4-core screened cable is supplied with a mating 4-pin M12 connector at one end and 4 wires at the other end. Available lengths are 2 m, 5 m and 10 m. Wire: cross sectional area 0.34 mm<sup>2</sup>  
Cable diameter: 5.6 ±0.2 mm

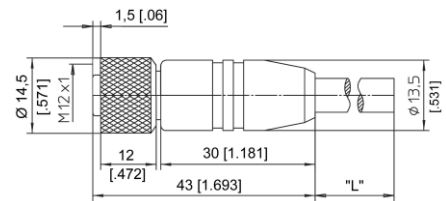

**Order code**

**KAB - xM - M12/4F/G - LITZE**

IP69: **KAB - xM - M12/4F/G/69K - LITZE**

xM = length in m

Signal wiring M12, 4 pin	Plug connection / cable color			
	1	2	3	4
	brown	white	blue	black

**Applicable for cable carriers**

Maximum movement speed	3 m/s
Maximum acceleration	5 m/s <sup>2</sup>
Minimum bending radius	10 x cable diameter

### Connector cable M12, 8 pin (angular coupling)

shielded connector

The 8-lead shielded cable is supplied with a mating 8-pin 90° M12 connector at one end and 8 wires at the other end. Available lengths are 2 m, 5 m and 10 m.  
Wire: cross sectional area 0.25 mm<sup>2</sup>  
Cable diameter: 6.3 ±0.2 mm

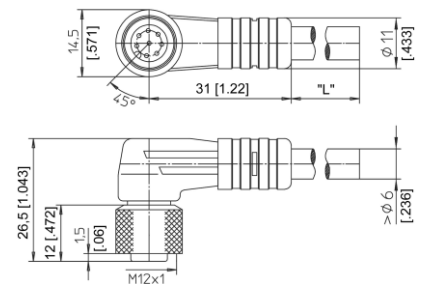

#### Order code

**KAB - xM - M12/8F/W - LITZE**

IP69: **KAB - xM - M12/8F/W/69K - LITZE**

xM = length in m

### Connector cable M12, 8 pin (straight coupling)

shielded connector

The 8-lead shielded cable is supplied with a mating 8-pin M12 connector at one end and 8 wires at the other end. Available lengths are 2 m, 5 m and 10 m.  
Wire: cross sectional area 0.25 mm<sup>2</sup>  
Cable diameter: 6.3 ±0.2 mm

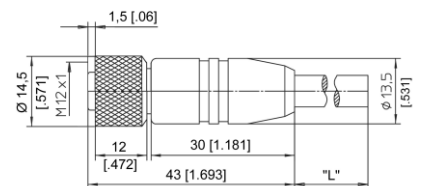

#### Order code

**KAB - xM - M12/8F/G - LITZE**

IP69: **KAB - xM - M12/8F/G/69K - LITZE**

xM = length in m

Signal wiring M12, 8 pin	Plug connection / cable color							
	1	2	3	4	5	6	7	8
	white	brown	green	yellow	grey	pink	blue	red

#### Applicable for cable carriers

Maximum movement speed	3 m/s
Maximum acceleration	5 m/s <sup>2</sup>
Minimum bending radius	10 x cable diameter