

CD120L-MEC mechanical device - Measurement range 0 up to 3500 mm

Specifications:

Measurement range	0 to 3500 mm
Drum circumference	300 mm/turn
Sensing device	Mounting with an optical encoder or any other rotary device (consult us)
Material	Body and cover - aluminium (RohS) Measuring cable – Stainless steel
Cable diameter	0,60 mm
Standard linearity	+/- 0,05% f.s. +/- 0,01% f.s. (optional)
Max. Velocity	10 m/s
Max. Acceleration	7 m/s ² (before cable deformation)
Weight	≈ 2000 g
Operating temperature	-20° to +85°C
Storage temperature	-30° to +85°C

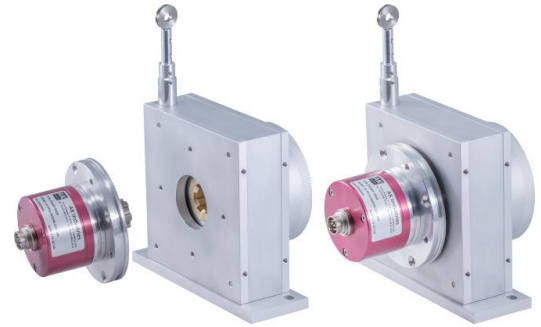

Cable forces:

Measurement range in mm	Min. pull-out force	Max. pull-out force
3500	≈ 13,00 N	≈ 18,00 N

Ordering reference:

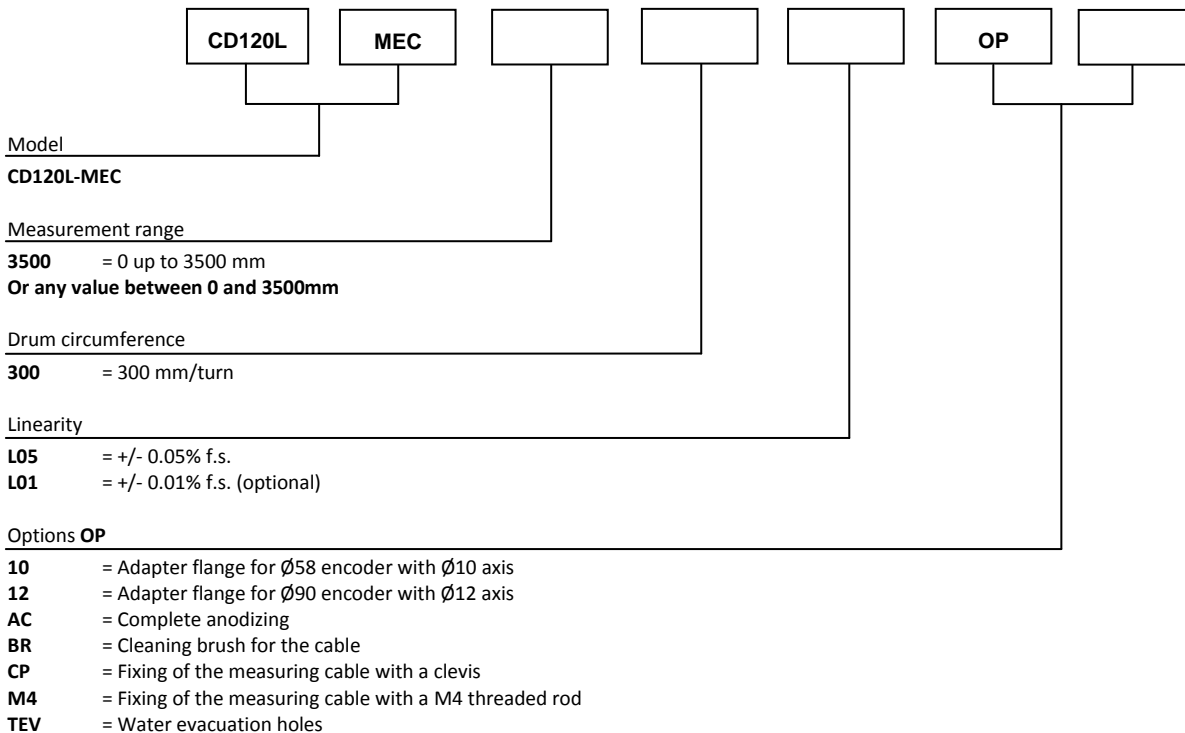

Reference example: CD120L-MEC-3500-300-L05-OP-10-AC



Options :

Cable attachment with a lug :

Standard

The attachment lug is fixed with a M6 screw or a clevis.

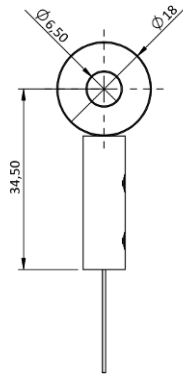

Cable attachment fitted with a M4 threaded rod:

OP-M4

The rod attachment uses a threaded rod with 2 nuts (provided). The required thickness of the plate does not exceed 5 mm.

Caution

Never screw the threaded rod into a fixed nut, a twist of the measurement cable would damage it.

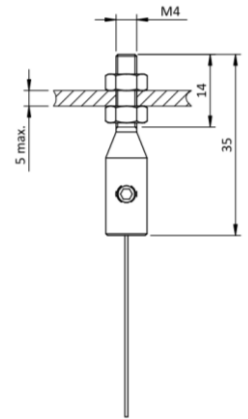

Cable attachment with a clevis :

OP-CP

The attachment of the clevis is done using a pin (provided)

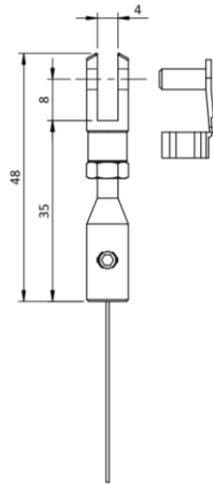

Cable cleaning brush

OP-BR

The cleaning brush wipes the cable in dusty or humid environments

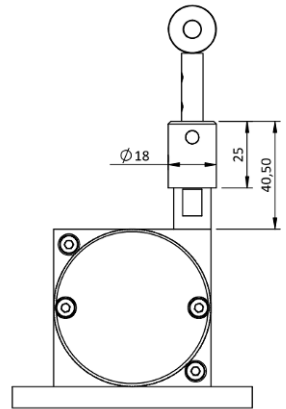

Water evacuation holes

OP-TEV

The holes allow the natural flow of fluids out of the sensor in order to avoid their accumulation in the system

Water evacuation holes
4 M3 screws
Remove the lowest screw
to allow
fluid evacuation

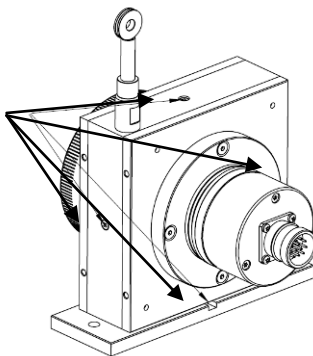

Encoder mounting instruction

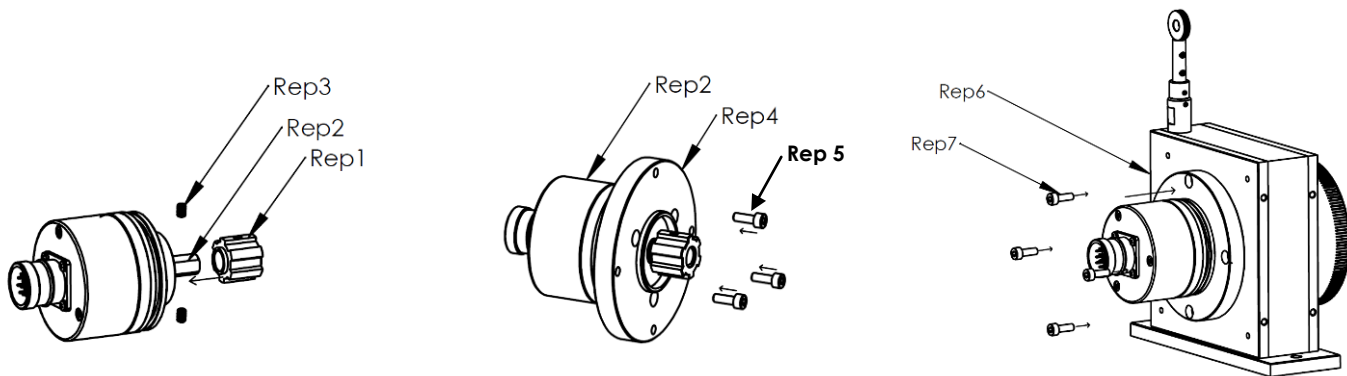

Slide the splined hub (Rep 1) onto the encoder shaft (Rep 2) and tighten both M4x6 grub screws (Rep 3)

Fix the flange (Rep 4) on the encoder (Rep 2) using the 3 CHC M4x12 screws (Rep 5)

Slide the flange + encoder assembly into the cable sensor groove (Rep 6) and secure with the 4 CHC M4x12 screws (Rep 7).

Changing the encoder position

1. Unscrew the 4 CHC M4x12 screws
2. Rotate the encoder by 90° increments
3. Screw the 4 CHC M4x12 screws

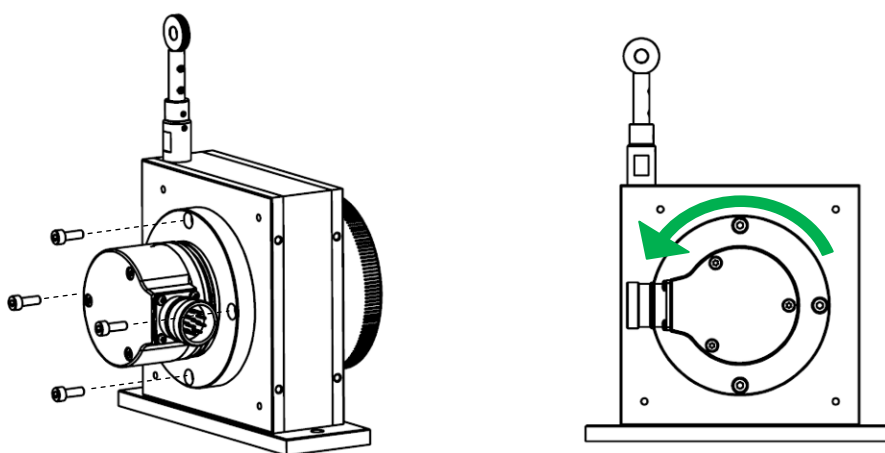

Changing the base plate position

1. Unscrew the 4 M4x10 screws holding the base plate
2. Position the base plate on the desired face
3. Fix the base plate using the 4 screws M4x10

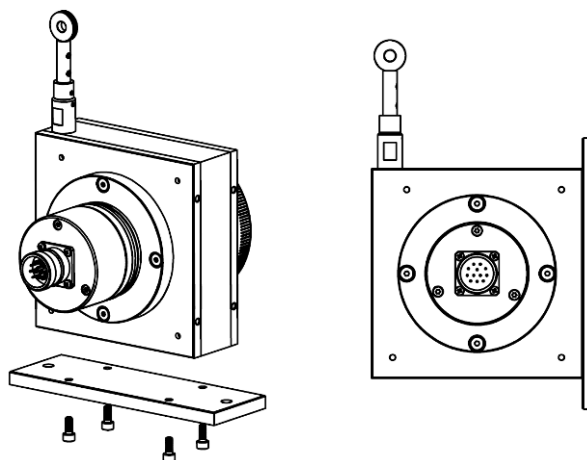

Dimensional drawings

